



# CPC504

**3U CompactPCI  
Intel Core 2 Duo Based  
Processor Module**

## User Manual

Rev. 002a E  
October 2011



*The product described in this manual is compliant  
with all related CE standards.*

Product Title: CPC504  
Document name: CPC504 User Manual  
Manual version: 002a E  
Ref. docs: CPC504-UM-v1.05-R

Copyright © 2011 Fastwel Co. Ltd. All rights reserved.

## Revision Record

Rev. Index	Brief Description	Product Index	Date
001	Initial preliminary version	CPC504, MIC584, MIC588	October 2010
002	Multiple amendments	CPC504, MIC584, MIC588	September 2011
002a	Reviewed names of connectors	CPC504, MIC584, MIC588	October 2011

## Contact Information

**Fastwel Co. Ltd**  
Address: 108 Profsoyuznaya st.,  
Moscow 117437,  
Russian Federation

Tel.: +7 (495) 232-1681

Fax: +7 (495) 232-1654

E-mail: [info@fastwel.com](mailto:info@fastwel.com)

Web: <http://www.fastwel.com/>

**Fastwel Corporation US**  
45 Main Street, Suite 319  
Brooklyn, New York 11201  
USA

+1 (718) 554-3686

+1 (718) 797-0600

Toll free: +1 (877) 787-8443 (1-877-RURUGGED)

## Table of Contents

Table of Contents .....	1
List of Tables .....	3
List of Figures .....	4
Notation Conventions.....	5
General Safety Precautions.....	6
Unpacking, Inspection and Handling.....	7
Three Year Warranty.....	8
<b>1 Introduction.....</b>	<b>9</b>
1.1 Overview .....	9
1.2 CPC504 Versions.....	11
1.3 CPC504 Diagrams .....	12
1.3.1 Block Diagram .....	13
1.3.2 Module Appearance.....	14
1.3.3 Module Layout .....	17
1.3.4 Module Dimensions.....	19
1.3.5 Front Panel.....	21
1.4 Technical Characteristics.....	23
1.4.1 Processor, Memory and Chipset.....	23
1.4.2 Interfaces .....	24
1.4.3 Control and Monitoring.....	26
1.4.4 General .....	27
1.4.5 Software.....	27
1.5 Delivery Checklist.....	28
1.6 System Expansion Modules.....	28
<b>2 Detailed Description .....</b>	<b>30</b>
2.1 Processor, Memory and Chipset.....	30
2.1.1 Processor .....	30
2.1.2 System Memory.....	30
2.1.3 Intel® Chipset.....	31
2.2 Internal Peripherals .....	31
2.2.1 Timers.....	31
2.2.1.1 Watchdog Timer .....	32
2.2.2 Battery.....	38
2.2.3 Local SMBus Devices .....	38
2.2.4 Flash Memory.....	39
2.2.4.1 NAND Flash .....	39
2.2.4.2 Secure Digital Socket.....	39
2.2.4.3 FRAM Emergency Storage for User Data .....	39
2.3 Module Interfaces.....	42
2.3.1 CompactPCI Bus Connectors.....	42
2.3.1.1 CompactPCI Connector Color Coding.....	42
2.3.1.2 CompactPCI Connectors J1 and J2 Pinouts.....	43
2.3.2 Connectors for Mezzanine Modules.....	45
2.3.3 Keyboard/Mouse Interface .....	46
2.3.4 USB Interfaces.....	46
2.3.5 Graphics Controller .....	47
2.3.5.1 DVM Technology .....	47
2.3.5.2 Supported Resolutions.....	47
2.3.5.3 CRT Interface and Connector.....	48
2.3.6 Serial Interfaces (RS232 and RS485).....	49
2.3.7 Parallel Port Interface.....	49

2.3.8	Gigabit Ethernet.....	49
2.3.9	Socket for Secure Digital Card.....	50
2.3.10	LED Indicators.....	50
2.3.10.1	L2 Indicator Configuration and Control Registers.....	51
2.3.10.2	LED Register Initialization.....	51
2.3.10.3	LED Register Bits.....	52
<b>3</b>	<b>Installation.....</b>	<b>53</b>
3.1	Safety Regulations.....	53
3.2	Installation Procedure.....	54
3.3	Removal Procedure.....	54
3.4	Peripheral Devices Installation.....	55
3.4.1	USB Devices Installation.....	55
3.4.2	Secure Digital Cards Installation.....	55
3.4.3	Battery Replacement.....	55
3.5	Installation of MIC584 Mezzanine Expansion Module.....	56
<b>4</b>	<b>Configuration.....</b>	<b>57</b>
4.1	PCI Express Operation Modes.....	57
4.2	Clear CMOS.....	57
<b>5</b>	<b>Phoenix® BIOS Setup.....</b>	<b>58</b>
5.1	Boot Details.....	58
5.1.1	Booting without a Monitor, Keyboard or Mouse.....	58
5.1.2	Booting from USB.....	58
<b>6</b>	<b>Thermal and Power Issues.....</b>	<b>59</b>
6.1	Temperature Control.....	59
6.1.1	Passive Regulation.....	59
6.1.2	Active Regulation.....	60
6.2	System Power.....	60
<b>7</b>	<b>MIC584 Mezzanine Expansion Module.....</b>	<b>61</b>
7.1	Introduction.....	61
7.1.1	MIC584 Versions.....	61
7.1.2	MIC584 Delivery Checklist.....	61
7.2	MIC584 Appearance and Layout.....	62
7.2.1	MIC584 Appearance.....	62
7.2.2	MIC584 Components Layout.....	64
7.3	Specifications.....	68
7.4	MIC584 Block Diagram.....	69
7.5	MIC584 Interfaces.....	70
7.5.1	MIC584 Interfaces List.....	70
7.5.1.1	Front Panel (4HP) Interfaces.....	70
7.5.1.2	Internal Interfaces.....	70
7.5.2	MIC584 Interfaces Detailed Description.....	71
7.5.2.1	Serial Interfaces.....	71
7.5.2.2	USB Interfaces.....	72
7.5.2.3	PS/2 Keyboard/Mouse Interface.....	73
7.5.2.4	Audio Interface.....	73
7.5.2.5	L3 and L4 LEDs.....	74
7.5.2.6	LPT Interface.....	74
7.5.2.7	SerialATA Interface.....	75
<b>8</b>	<b>MIC588 2×DVI Module.....</b>	<b>76</b>
8.1	Introduction.....	76
8.2	Specifications.....	76
8.3	MIC588 Block Diagram.....	77
8.4	MIC588 Layout.....	78
8.5	DVI-D Connectors.....	79

<b>9</b>	<b>Supplementary Information</b> .....	<b>80</b>
9.1	Related Standards and Specifications.....	80
<b>10</b>	<b>Useful Abbreviations, Acronyms and Short-cuts</b> .....	<b>81</b>

## List of Tables

Table 1-1:	Off-the-Shelf Configurations of CPC504.....	11
Table 1-2:	Dimensions for Different Types of Heatsinks .....	19
Table 1-3:	Interface Expansion Modules.....	28
Table 2-1:	SMBus Devices.....	38
Table 2-2:	CompactPCI Connector Coding Colors .....	42
Table 2-3:	CompactPCI Bus Connector J1 (J6) System Slot Pinout.....	43
Table 2-4:	32-bit CompactPCI Bus Connector J2 (J3) System Slot Pinout.....	44
Table 2-5:	Pinout of J2 Connector for MIC584 Mezzanine Module.....	45
Table 2-6:	USB1 and USB2 Pinouts (CPC504 Front Panel).....	46
Table 2-7:	Partial List of Supported Display Modes .....	48
Table 2-8:	SVGA (J45) Front Panel Connector Pinout.....	48
Table 2-9:	Gigabit Ethernet Connectors Pinouts.....	49
Table 2-10:	L1 and L2 Front Panel Indicators .....	50
Table 2-11:	L2 Indicator Configuration and Control Registers .....	51
Table 2-12:	LED Control Register Bits .....	52
Table 2-13:	L2 LED Operation Modes .....	52
Table 4-1:	PCI Express Operation Mode Selection.....	57
Table 6-1:	DC Input Voltage Ranges and Limits.....	60
Table 7-1:	MIC584 Versions Differences.....	61
Table 7-2:	COM1 Serial Port Pinout.....	71
Table 7-3:	RS-232 COM2-COM4 (XP11-XP13) Pinout.....	71
Table 7-4:	RS-485 COM5 and COM6 (XP7) Pinout.....	72
Table 7-5:	USB3 and USB4 Connectors Pinout.....	72
Table 7-6:	PS/2 Connector Pinout .....	73
Table 7-7:	"LINE_IN" (XP5) Connector Pinout.....	73
Table 7-8:	"LINE_OUT" (XP6) Connector Pinout.....	74
Table 7-9:	LPT Connector Pinout .....	74
Table 7-10:	SerialATA Connector Pinout .....	75
Table 8-1:	DVI-D Connector Pinout .....	79
Table 9-1:	Related Standards.....	80
Table 9-2:	Related Specifications .....	80

## List of Figures

Figure 1-1:	CPC504 Block Diagram.....	13
Figure 1-2:	CPC504 Module Appearance with R2 Heatsink .....	14
Figure 1-3:	CPC504 Module Appearance Without Heatsink.....	15
Figure 1-4:	CPC504-03 and -04 Bottom Side.....	16
Figure 1-5:	CPC504 Module Layout: Top Side.....	17
Figure 1-6:	CPC504-03 and -04 Module Layout: Bottom Side.....	18
Figure 1-7:	CPC504 Module Dimensions with R1 Heatsink.....	19
Figure 1-8:	CPC504-01/02 Module Dimensions with R2 Heatsink (8HP) .....	20
Figure 1-9:	CPC504-03/04 Module Dimensions with R1 Heatsink and MIC588 .....	20
Figure 1-10:	CPC504-03/04 Module Dimensions with R2 Heatsink and MIC588 .....	20
Figure 1-11:	CPC504-01/02 4HP Front Panel .....	21
Figure 1-12:	CPC504-03/04 Front Panel.....	22
Figure 2-1:	CompactPCI Connectors J1 and J2 → .....	42
Figure 2-2:	J2 Expansion Connector for MIC584 Mezzanine Module .....	45
Figure 2-3:	USB1 (J22) и USB2 (J16) Sockets.....	46
Figure 2-4:	SVGA (J45) Front Panel Connector .....	48
Figure 2-5:	Ethernet Connectors.....	49
Figure 2-6:	SD Card Socket .....	50
Figure 3-1:	Fixing of MIC584 on CPC504.....	56
Figure 7-1:	MIC584 Appearance.....	62
Figure 7-2:	MIC584 Appearance with SATA SSD Installed .....	63
Figure 7-3:	MIC584 Components Layout and Dimensions (Top) .....	64
Figure 7-4:	MIC584 Components Layout (Bottom).....	65
Figure 7-5:	MIC584 with 160 GB SSD Installed.....	66
Figure 7-6:	MIC584 Front Panel .....	67
Figure 7-7:	CPC504 Block Diagram.....	69
Figure 7-8:	COM1 Front Panel Connector.....	71
Figure 7-9:	COM2-COM6 Serial Ports IDC2-10 Connector .....	71
Figure 7-10:	USB3 and USB4 Connectors .....	72
Figure 7-11:	PS/2 Connector.....	73
Figure 7-12:	LINE_IN (XP5) and LINE_OUT (XP6) Connectors .....	73
Figure 7-13:	LPT Connector (XP2) .....	74
Figure 7-14:	SerialATA Connector.....	75
Figure 8-1:	MIC588 Block Diagram.....	77
Figure 8-2:	MIC588 Layout (Side Facing CPC504).....	78

All information in this document is provided for reference only, with no warranty of its suitability for any specific purpose. This information has been thoroughly checked and is believed to be entirely reliable and consistent with the product that it describes. However, Fastwel accepts no responsibility for inaccuracies, omissions or their consequences, as well as liability arising from the use or application of any product or example described in this document.

Fastwel Co. Ltd. reserves the right to change, modify, and improve this document or the products described in it, at Fastwel's discretion without further notice. Software described in this document is provided on an "as is" basis without warranty. Fastwel assumes no liability for consequential or incidental damages originated by the use of this software.

This document contains information, which is property of Fastwel Co. Ltd. It is not allowed to reproduce it or transmit by any means, to translate the document or to convert it to any electronic form in full or in parts without antecedent written approval of Fastwel Co. Ltd. or one of its officially authorized agents.

Fastwel and Fastwel logo are trademarks owned by Fastwel Co. Ltd., Moscow, Russian Federation. CompactPCI is a trademark of the PCI Industrial Computers Manufacturers Group. Ethernet is a registered trademark of Xerox Corporation. IEEE is a registered trademark of the Institute of Electrical and Electronics Engineers Inc. Intel is a trademark of Intel Corporation. Pentium M and Celeron M are trademarks of Intel Corporation. Microsoft is a trademark of the Microsoft corporation. In addition, this document may include names, company logos and trademarks, which are registered trademarks and, therefore, are property of their respective owners.

Fastwel welcomes suggestions, remarks and proposals regarding the form and the content of this Manual.

## Notation Conventions



### **Warning, ESD Sensitive Device!**

This symbol draws your attention to the information related to electro static sensitivity of your product and its components. To keep product safety and operability it is necessary to handle it with care and follow the ESD safety directions.



### **Warning!**

This sign marks warnings about hot surfaces. The surface of the heatsink and some components can get very hot during operation. Take due care when handling, avoid touching hot surfaces!



### **Caution: Electric Shock!**

This symbol warns about danger of electrical shock (> 60 V) when touching products or parts of them. Failure to observe the indicated precautions and directions may expose your life to danger and may lead to damage to your product.



### **Warning!**

Information marked by this symbol is essential for human and equipment safety. Read this information attentively, be watchful.



### **Note...**

This symbol and title marks important information to be read attentively for your own benefit.

## General Safety Precautions

This product was developed for fault-free operation. Its design provides conformance to all related safety requirements. However, the life of this product can be seriously shortened by improper handling and incorrect operation. That is why it is necessary to follow general safety and operational instructions below.



### Warning!

All operations on this device must be carried out by sufficiently skilled personnel only.



### Warning!

When handling this product, special care must be taken not to hit the heatsink (if installed) against another rigid object. Also, be careful not to drop the product, since this may cause damage to the heatsink, CPU or other sensitive components as well.

Please, keep in mind that any physical damage to this product is not covered under warranty.



### Note:

This product is guaranteed to operate within the published temperature ranges and relevant conditions. However, prolonged operation near the maximum temperature is not recommended by Fastwel or by electronic chip manufacturers due to thermal stress related failure mechanisms. These mechanisms are common to all silicon devices, they can reduce the MTBF of the product by increasing the failure probability. Prolonged operation at the lower limits of the temperature ranges has no limitations.



### Caution, Electric Shock!

Before installing this product into a system and before installing other devices on it, always ensure that your mains power is switched off.

Always disconnect external power supply cables during all handling and maintenance operations with this module to avoid serious danger of electrical shock.



## Unpacking, Inspection and Handling

Please read the manual carefully before unpacking the module or mounting the device into your system. Keep in mind the following:



### ESD Sensitive Device!

Electronic modules and their components are sensitive to static electricity. Even a non-perceptible by human being static discharge can be sufficient to destroy or degrade a component's operation! Therefore, all handling operations and inspections of this product must be performed with due care, in order to keep product integrity and operability:

- Preferably, unpack or pack this product only at EOS/ESD safe workplaces. Otherwise, it is important to be electrically discharged before touching the product. This can be done by touching a metal part of your system case with your hand or tool. It is particularly important to observe anti-static precautions when setting jumpers or replacing components.
- If the product contains batteries for RTC or memory back-up, ensure that the module is not placed on conductive surfaces, including anti-static mats or sponges. This can cause short-circuit and result in damage to the battery and other components.
- Store this product in its protective packaging while it is not used for operational purposes.

### Unpacking

The product is carefully packed in an antistatic bag and in a carton box to protect it against possible damage and harmful influence during shipping. Unpack the product indoors only at a temperature not less than +15°C and relative humidity not more than 70%. Please note, that if the product was exposed to the temperatures below 0°C for a long time, it is necessary to keep it at normal conditions for at least 24 hours before unpacking. Do not keep the product close to a heat source.

Following ESD precautions, carefully take the product out of the shipping carton box. Proper handling of the product is critical to ensure correct operation and long-term reliability. When unpacking the product, and whenever handling it thereafter, be sure to hold the module preferably by the front panel, card edges or ejector handles. Avoid touching the components and connectors.

Retain all original packaging at least until the warranty period is over. You may need it for shipments or for storage of the product.

### Initial Inspection

Although the product is carefully packaged, it is still possible that shipping damages may occur. Careful inspection of the shipping carton can reveal evidence of damage or rough handling. Should you notice that the package is damaged, please notify the shipping service and the manufacturer as soon as possible. Retain the damaged packing material for inspection.

After unpacking the product, you should inspect it for visible damage that could have occurred during shipping or unpacking. If damage is observed (usually in the form of bent component leads or loose socketed components), contact Fastwel's official distributor from which you have purchased the product for additional instructions. Depending on the severity of the damage, the product may even need to be returned to the factory for repair. **DO NOT** apply power to the product if it has visible damage. Doing so may cause further, possibly irreparable damage, as well as result in a fire or electric shock hazard.

If the product contains socketed components, they should be inspected to make sure they are seated fully in their sockets.

## Handling

In performing all necessary installation and application operations, please follow only the instructions supplied by the present manual.

In order to keep Fastwel's warranty, you must not change or modify this product in any way, other than specifically approved by Fastwel or described in this manual.

Technical characteristics of the systems in which this product is installed, such as operating temperature ranges and power supply parameters, should conform to the requirements stated by this document.

Retain all the original packaging, you will need it to pack the product for shipping in warranty cases or for safe storage. Please, pack the product for transportation in the way it was packed by the supplier.

When handling the product, please, remember that the module, its components and connectors require delicate care. Always keep in mind the ESD sensitivity of the product.

## Three Year Warranty

Fastwel Co. Ltd. (Fastwel), warrants that its standard hardware products will be free from defects in materials and workmanship under normal use and service for the currently established warranty period. Fastwel's only responsibility under this warranty is, at its option, to replace or repair any defective component part of such products free of charge.

Fastwel neither assumes nor authorizes any other liability in connection with the sale, installation or use of its products. Fastwel shall have no liability for direct or consequential damages of any kind arising out of sale, delay in delivery, installation, or use of its products.

If a product should fail through Fastwel's fault during the warranty period, it will be repaired free of charge. For out of warranty repairs, the customer will be invoiced for repair charges at current standard labor and materials rates.

Warranty period for Fastwel products is 36 months since the date of purchase.

### **The warranty set forth above does not extend to and shall not apply to:**

1. Products, including software, which have been repaired or altered by other than Fastwel personnel, unless Buyer has properly altered or repaired the products in accordance with procedures previously approved in writing by Fastwel.
2. Products, which have been subject to power, supply reversal, misuse, neglect, accident, or improper installation.

### **Returning a product for repair**

1. Apply to Fastwel company or to any of the Fastwel's official representatives for the Product Return Authorization.
2. Attach a failure inspection report with a product to be returned in the form, accepted by customer, with a description of the failure circumstances and symptoms.
3. Carefully package the product in the antistatic bag, in which the product had been supplied. Failure to package in antistatic material will VOID all warranties. Then package the product in a safe container for shipping.
4. The customer pays for shipping the product to Fastwel or to an official Fastwel representative or dealer.

# 1 Introduction

## 1.1 Overview

The product described in this Manual is CPC504 – a 3U CompactPCI PICMG 2.0 host processor module based on low power dual-core Intel Core™ 2 Duo CPUs operating at 1.6 GHz or 2.2 GHz with 4 MB level 2 cache and featuring 800 MHz system bus. The processor executes up to 8 floating point operations per clock cycle and can address up to 4 GB of soldered DDR2 system memory in 64-bit mode. The list of processors includes also an ultra low voltage Intel Celeron 573 with 512 KB L2 cache operating at 1 GHz supporting 533 MHz FSB.

An increased heatsink for CPU and chipset cooling with effective surface area of up to 682 cm<sup>2</sup> allows efficient heat dissipation within wide ambient air temperature range.

For high-speed data exchange CPC504 employs two Gigabit Ethernet channels, four x1 PCI Express lanes configurable also as one x4 slot, and 32-bit PCI bus. The integrated graphics controller of Intel 965GME supports output of two independent video streams to VGA interface or to two DVI-D interfaces available at MIC588 mezzanine expansion module.

The firmware of CPC504 supports booting from LAN, from the onboard SD cards, from soldered 4 GB NAND flash memory disk, or from SATA II (up to 300 MB/s) drives located on MIC584 mezzanine expansion module or on a rear I/O module.

The MIC584 mezzanine module supports two SATA II interfaces with option to mount either SATA DOM solid-state modules or one standard 1.8" SATA disk drive. Six COM ports, two USB 2.0, PS/2, and audio interfaces are available via the MIC584 module as well.

CPC504 supports FreeDOS, Windows XP Embedded, and Linux 2.6 operating systems. (TBA)

Some of the CPC504's basic features are:

- 4HP, 3U CompactPCI form-factor
- Intel® processors:
  - Celeron ULV 573, 1.0 GHz, 512 KB L2 cache, 533 MHz FSB
  - Core™ 2 Duo L7500, 1.6 GHz, 4 MB L2 cache, 800 MHz FSB
  - Core™ 2 Duo T7500, 2.2 GHz, 4 MB L2 cache, 800 MHz FSB
- Intel chipset: 82965GME GMCH and ICH8M
- Up to 4 GB of soldered dual channel DDR2 SDRAM memory with 64-bit addressing
- PCI bus: 32-bit / 33 MHz (System master)
- PCI Express: four x1 or one x4 routed to rear I/O (\*)
- Flash BIOS:
  - SPI interface, 8 Mbit
  - In-system modification
- CMOS+SFRAM for configuration parameters storage
- FRAM: 31 KB available to user
- Watchdog timer:
  - Programmable timeout period
  - NMI, IRQ or Reset signals generation
- FPGA firmware upgrade capability
- Integrated high performance graphics controller:
  - 2D accelerator
  - Up to 384 MB memory shared with system
  - CRT displays support with resolutions of up to 2048x1536, 32 bits at 75 Hz
  - Dual SDVO support, front/rear output capability (\*)
  - VGA, two DVI-D interfaces
  - External graphics controller support via x16 PCI-E (\*)
- Secure Digital card socket
- Up to 4 GB soldered NAND flash disk with IDE interface
- SATA interface: 3 ports, SATA and SATA II support (\*)
- Gigabit Ethernet interfaces:
  - Two PCI-E controllers
  - 10/100/1000 Mbps
  - Front/rear switchable
- USB: 1.1 and 2.0 support, up to five devices (\*)
- Six serial ports via LPC interface (\*)
- Parallel port: IEEE1284, ECP/EPP, available at MIC584
- HD audio interface; Line In, Line Out, Headphones Out and Mic In (\*)
- PS/2 keyboard and mouse interface (\*)
- Real-time clock with battery backup; batteryless operation capability
- Self-control and monitoring system
- LED indicators
- Programmable ejector switch
- Phoenix® BIOS

(\*) – Available either on the CPC504, on Rear I/O or on mezzanine modules

## 1.2 CPC504 Versions

At the present time, the module is offered in flexible configuration. The options include different processors, the size of soldered system memory, and other options described in this section. Versions -03 and -04 of CPC504 are supplied with MIC588 expansion module (dual DVI-D interface) installed to the left of processor module.

All variants except C2D2.2 are available in two versions, for industrial (-40°C to +85°C) and for commercial (0°C to 70°C) temperature ranges. C2D2.2 is available for commercial temperature range only. At the present time CPC504 is available in the following off-the-shelf configurations:

**Table 1-1: Off-the-Shelf Configurations of CPC504**

Configuration	Variants
CPC504-01-C2D1.6-RAM4096	CPC504-01-C2D1.6-RAM4096-R1-C
	CPC504-01-C2D1.6-RAM4096-R2-I
CPC504-02-CS1.0-RAM2048	CPC504-02-CS1.0-RAM2048-R1-C
	CPC504-02-CS1.0-RAM2048-R1-I
CPC504-02-C2D1.6-RAM2048	CPC504-02-C2D1.6-RAM2048-R1-C
	CPC504-02-C2D1.6-RAM2048-R2-I
CPC504-02-C2D2.2-RAM4096	CPC504-02-C2D2.2-RAM4096-R2-C (commercial range only)
PC504-03-C2D2.2-RAM4096	CPC504-03-C2D2.2-RAM4096-R2-C (commercial range only)
CPC504-04-C2D1.6-RAM4096	CPC504-04-C2D1.6-RAM4096-R1-C
	CPC504-04-C2D1.6-RAM4096-R2-I

Other configuration options are available upon request. The customer can choose necessary configuration options using the following template:

1	-	2	-	3	-	4	-	5	-	6	\	7
---	---	---	---	---	---	---	---	---	---	---	---	---

1 Basic product name:  
CPC504

2 Version:

Version	NAND Flash 4096	2xDVI-D
01	+	-
02	-	-
03	+	+
04	-	+

3 Processor:

CS1.0	Intel Celeron ULV 573 (512 KB L2 cache, 1.00 GHz, 533 MHz FSB), 10 W
C2D1.6	Intel Core 2 Duo L7500 (4 MB L2 cache, 1.6 GHz, 800 MHz FSB), 17 W
C2D2.2	Intel Core 2 Duo T7500 (4 MB L2 cache, 2.2 GHz, 800 MHz FSB), 35 W (C2D2.2 - commercial range only)

- 4 System memory:
  - RAM2048 2048 MB soldered DDR2 SDRAM
  - RAM4096 4096 MB soldered DDR2 SDRAM
- 5 Heatsinks:
  - R1 Low profile, 4HP
  - R2 High profile, 8HP
- 6 Operating temperature range:
  - C Commercial, 0°C to +70°C
  - I Industrial, -40°C to +85°C
- 7 Other options:
  - Coating
    - \COATED Protective Coating
  - Operating System
    - \XPE Windows XP Embedded
    - \LNX Linux 2.6

Example:

**CPC504 – 01 – CS1.0 – RAM2048 – R1 – C**

3U CompactPCI processor module,  
 4096 MB soldered NAND flash disk,  
 Intel Celeron ULV 573 CPU (512 KB L2 cache, 1.0 GHz, 533 MHz FSB),  
 2048 MB soldered DDR2 SDRAM,  
 Low profile heatsink,  
 Commercial operating temperature range, 0°C to +70°C

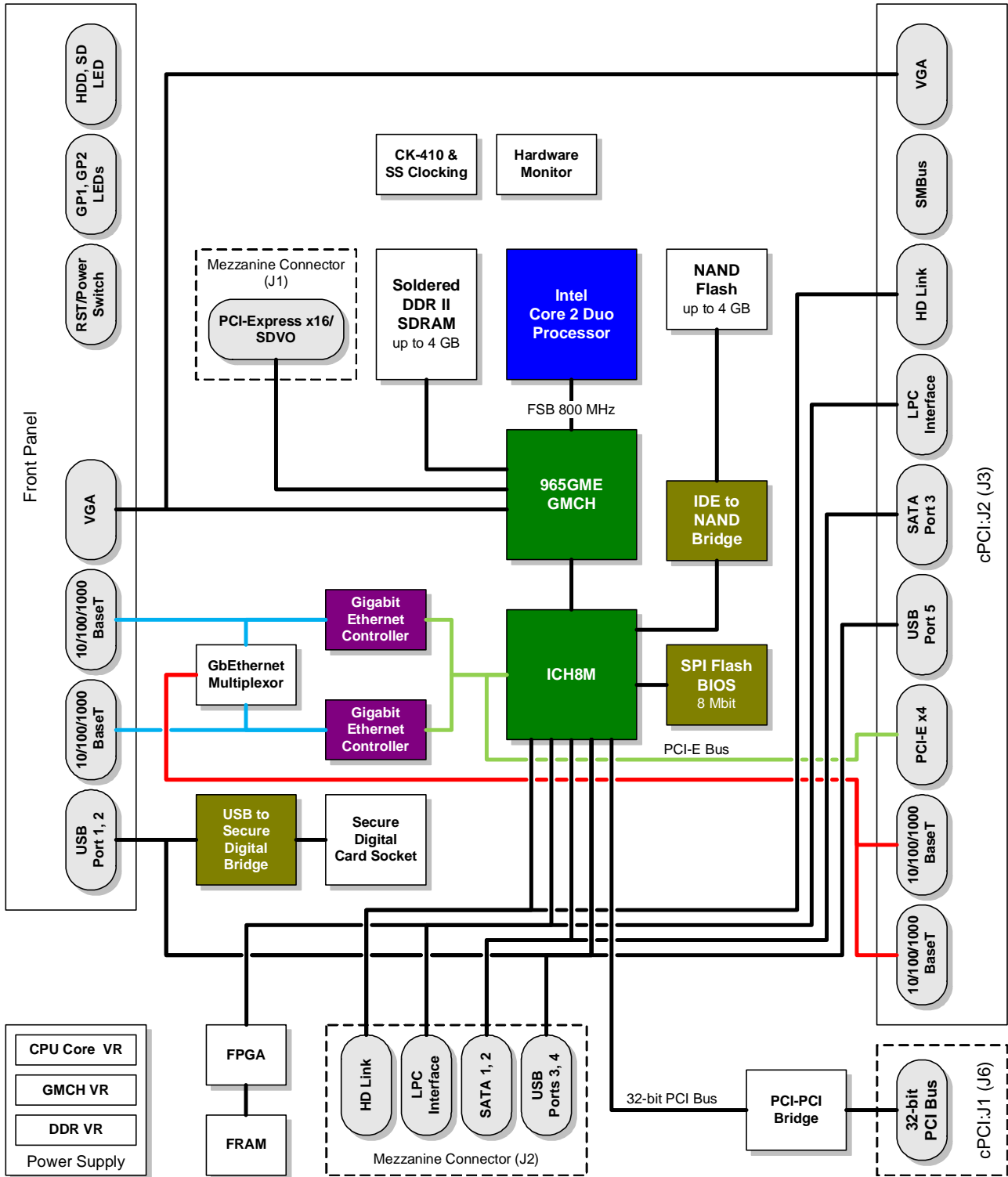
## 1.3 CPC504 Diagrams

The diagrams in this section give visual information about the CPC504 module design, its appearance, connectors and components layout. The diagrams may not reflect insignificant differences between the CPC504 versions.



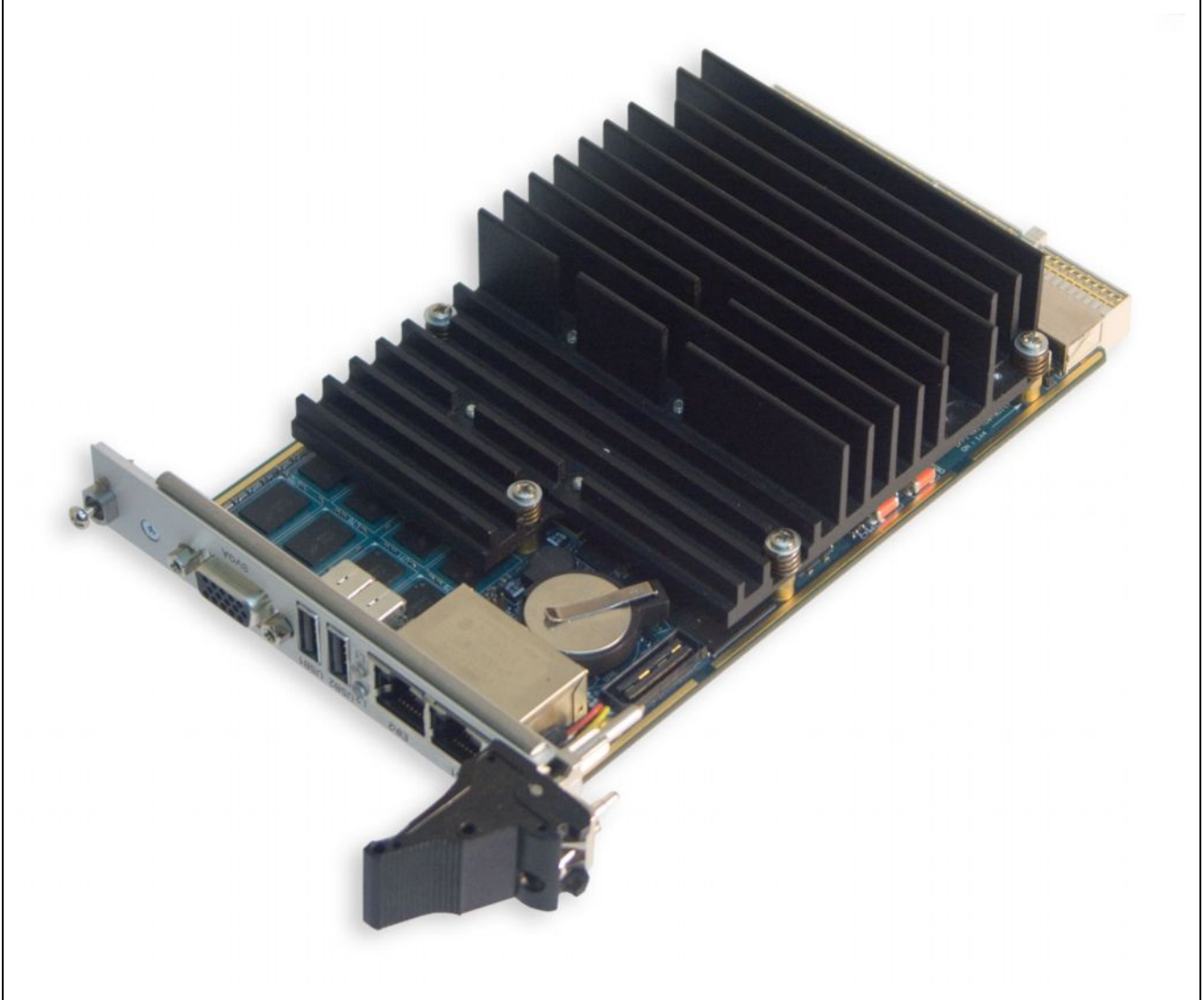
### 1.3.1 Block Diagram

Figure 1-1: CPC504 Block Diagram



### 1.3.2 Module Appearance

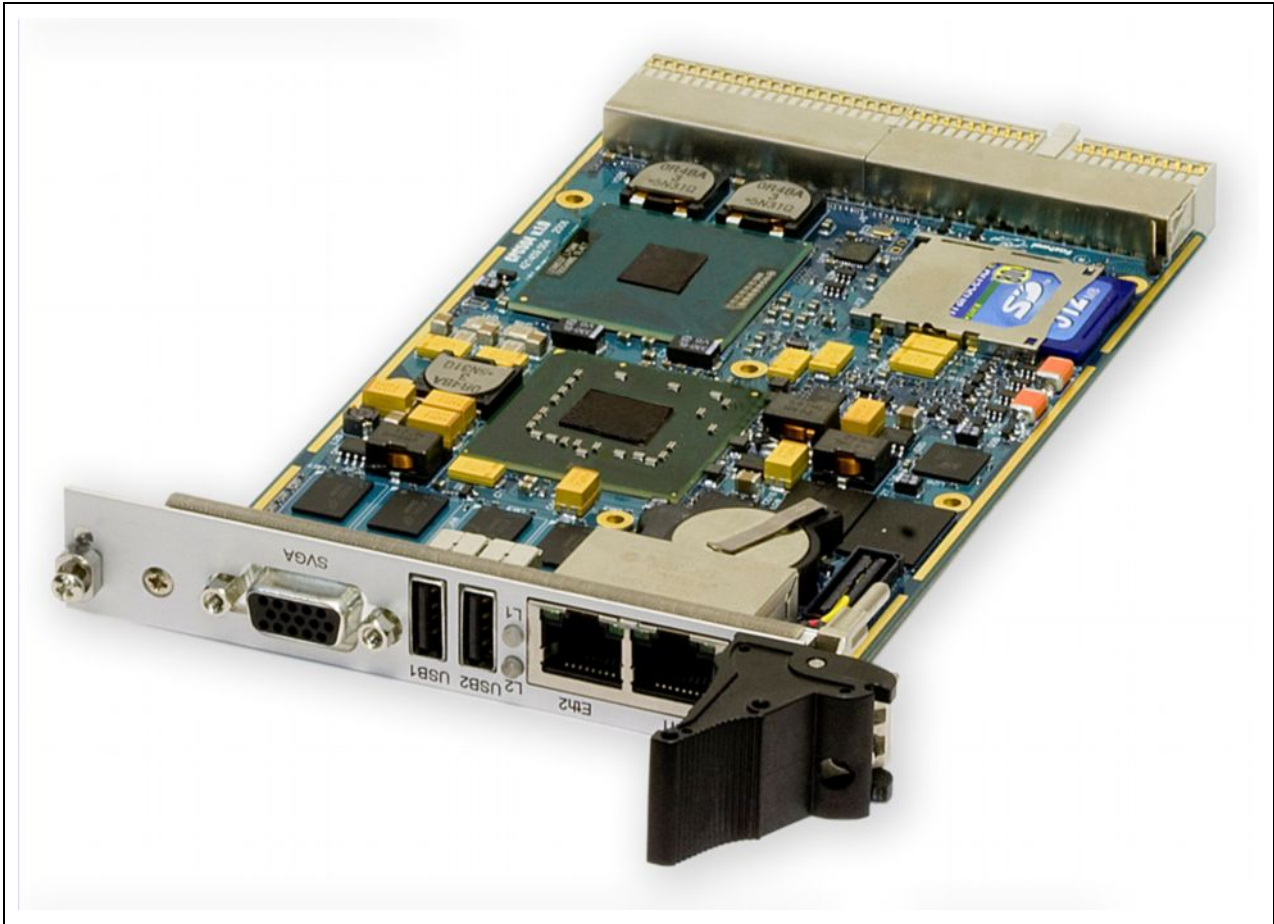
Figure 1-2: CPC504 Module Appearance with R2 Heatsink



*The appearance may vary for different versions of the module.*

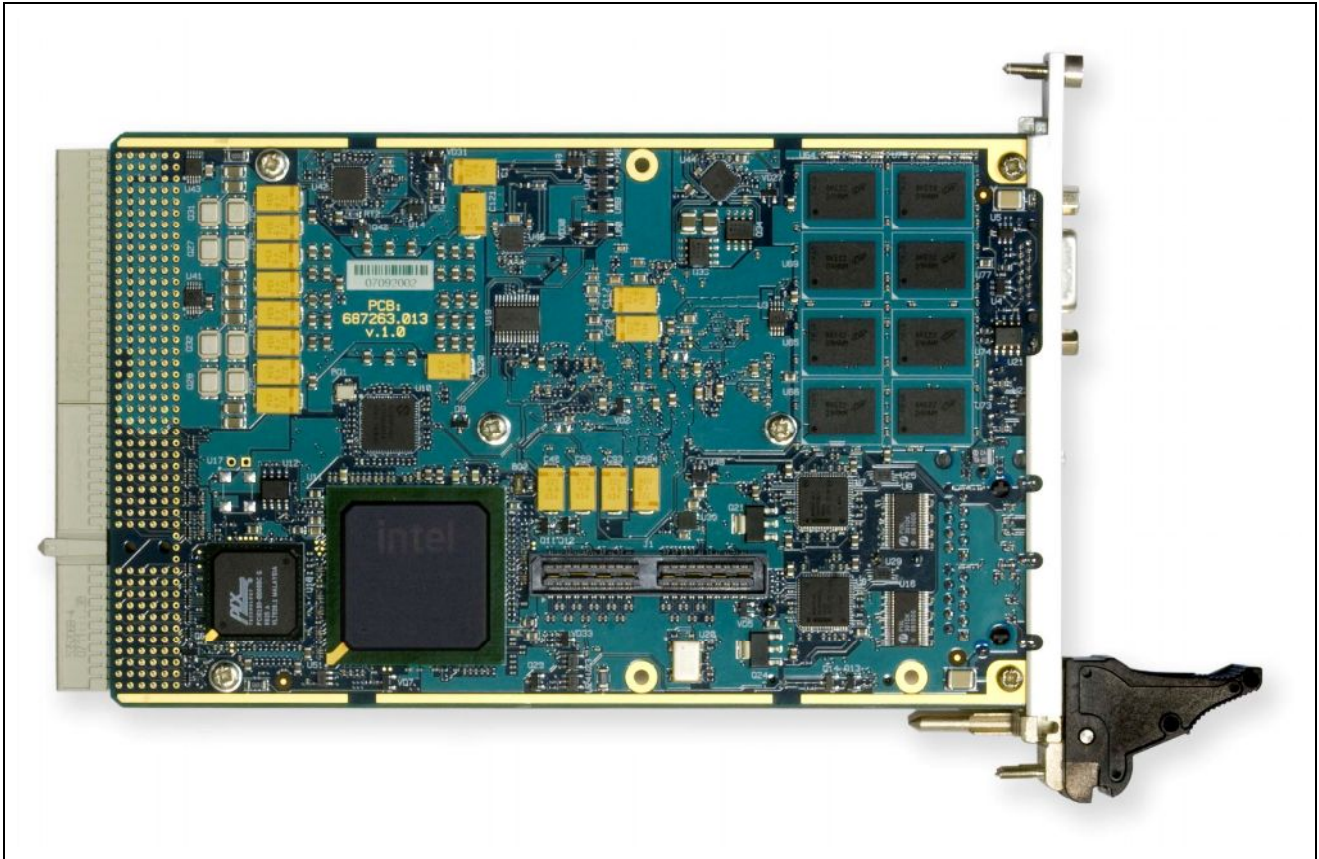


Figure 1-3: CPC504 Module Appearance Without Heatsink



*The appearance may vary for different versions of the module.*

Figure 1-4: CPC504-03 and -04 Bottom Side

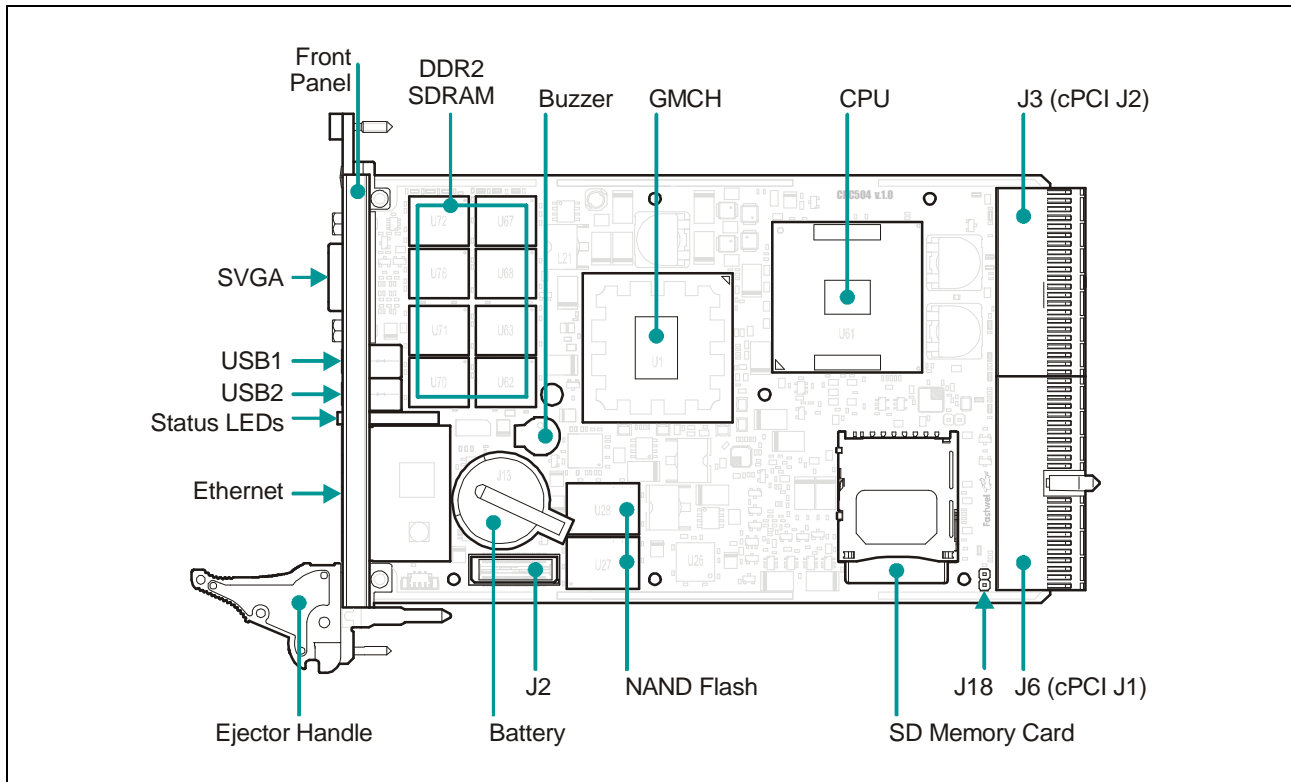


*The appearance may vary for different versions of the module.*

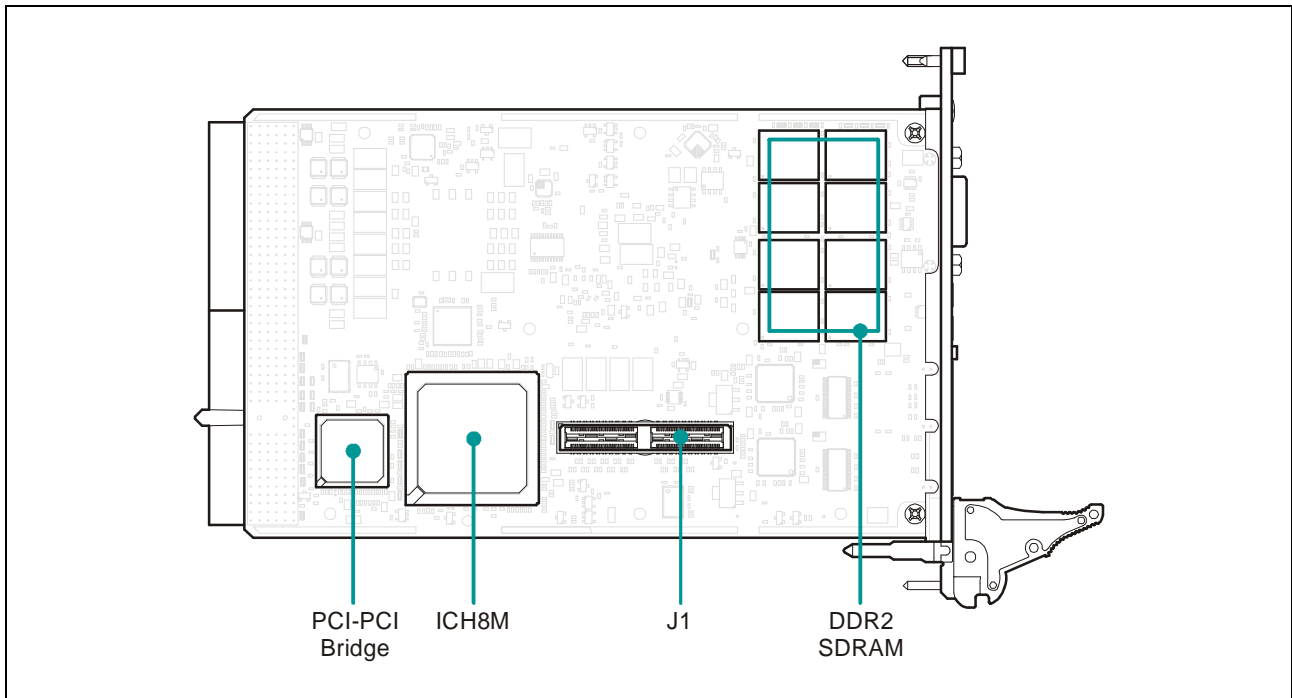
*MIC588 is not shown. Versions -01 and -02 are not equipped with J1 connector.*

### 1.3.3 Module Layout

Figure 1-5: CPC504 Module Layout: Top Side



*The layout may slightly differ for various versions of the module.  
Heatsink is not shown.*

**Figure 1-6: CPC504-03 and -04 Module Layout: Bottom Side**

*The layout may slightly differ for various versions of the module.*

*MIC588 is not shown. Versions -01 and -02 are not equipped with J1 connector.*

### 1.3.4 Module Dimensions

Figure 1-7: CPC504 Module Dimensions with R1 Heatsink

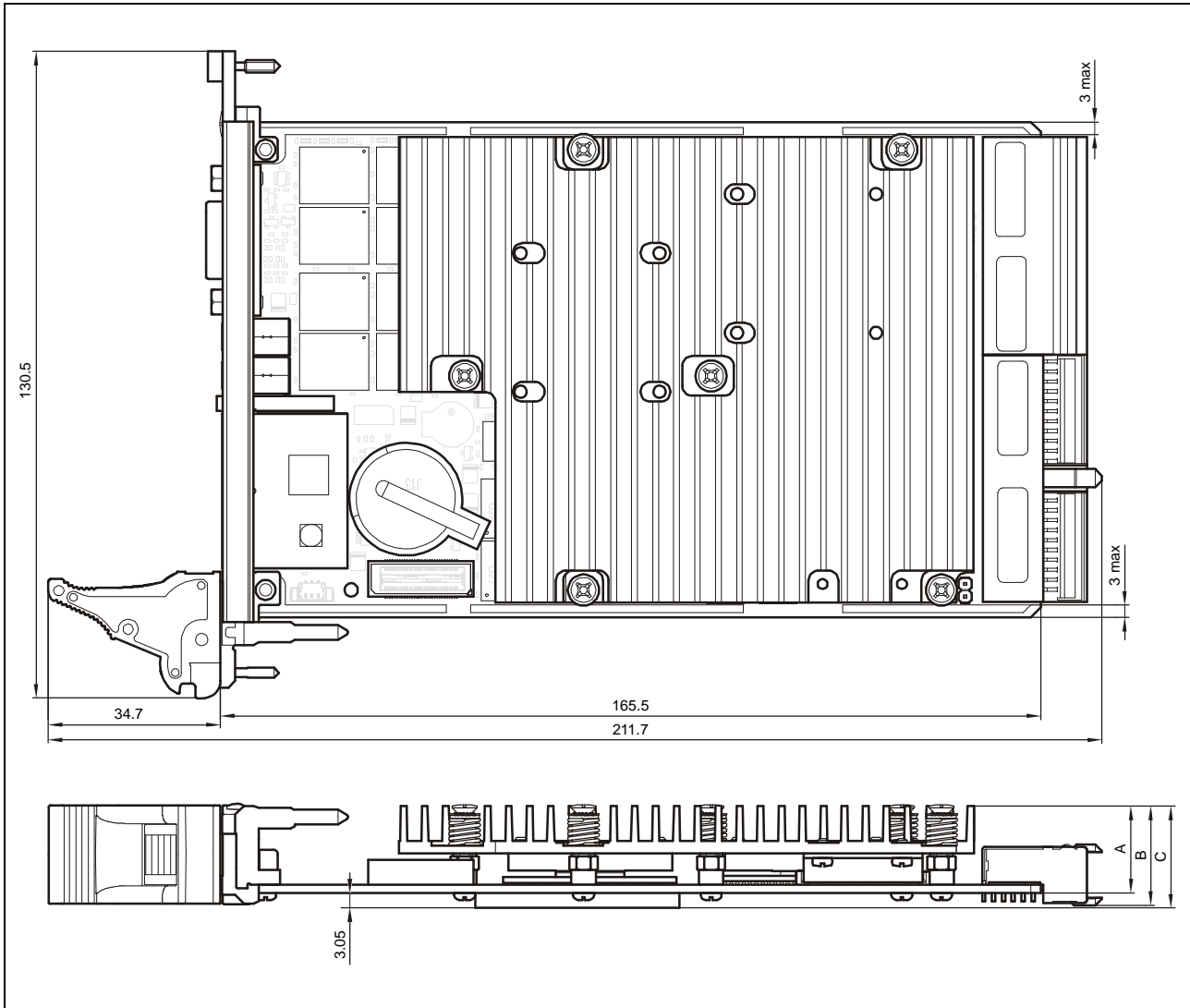
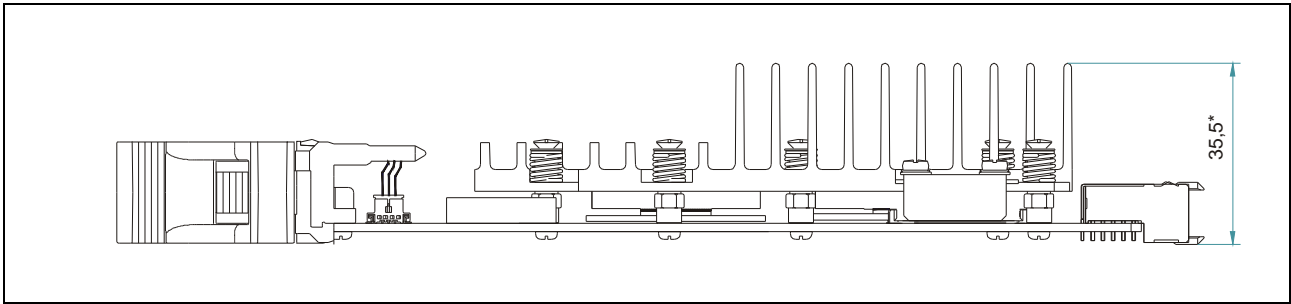
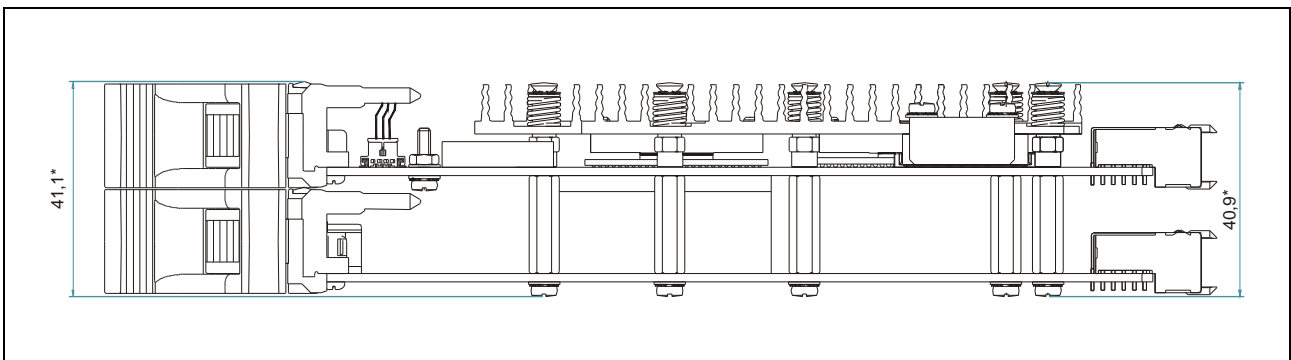
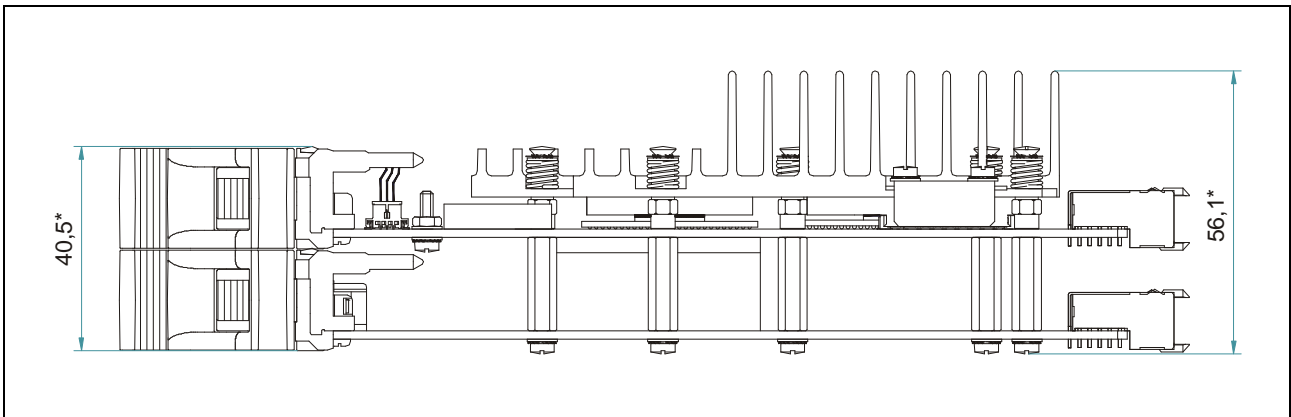


Table 1-2: Dimensions for Different Types of Heatsinks

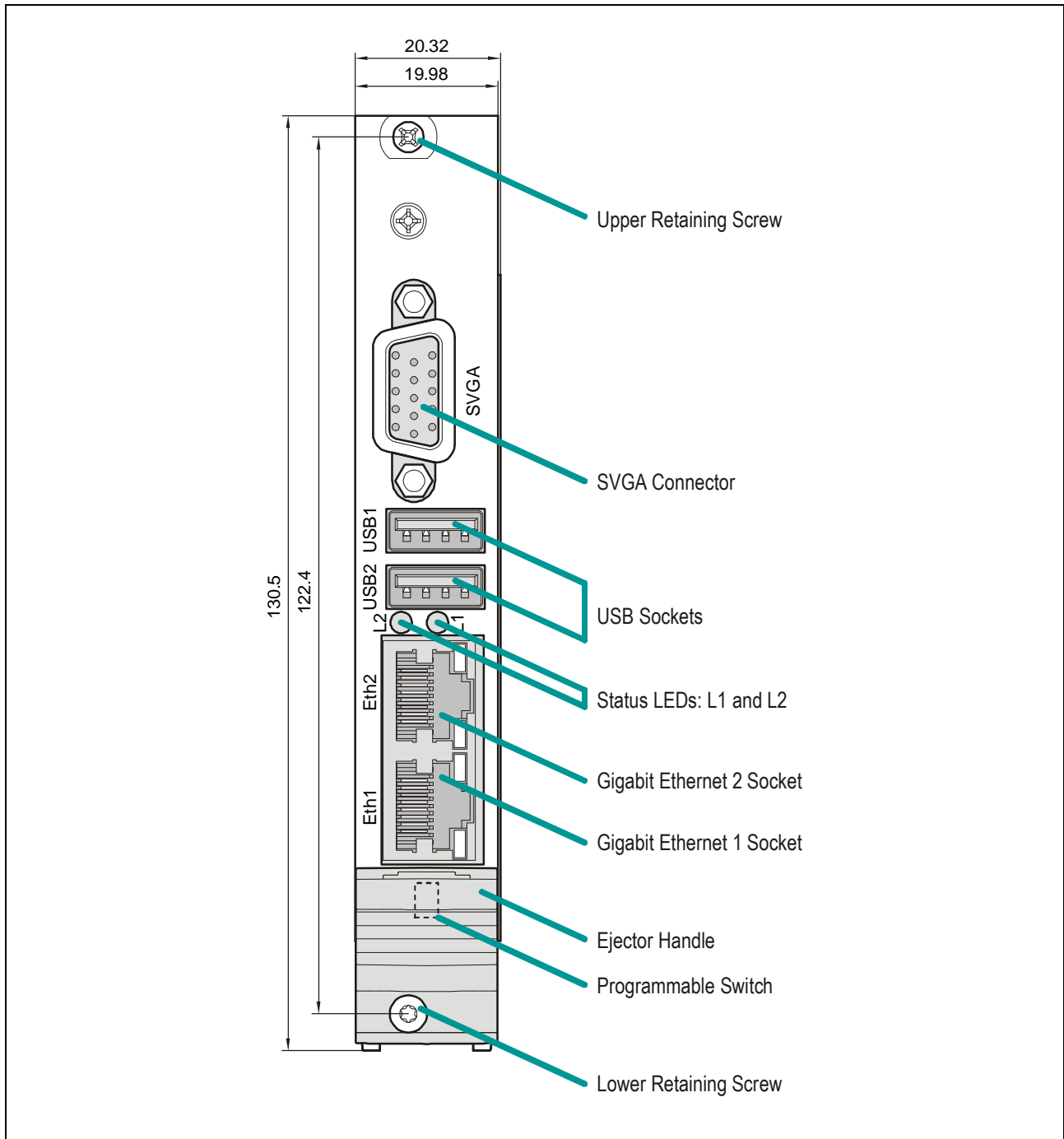
Fastwel Code	Heatsink Model & Manufacturer	Type	A	B	C
301415.019	0SX77 AavidThermalloy	R1	17.5	20	20.5
301415.019-02	0SX98 AavidThermalloy	R2	29	31.5	32
301415.019-03	SK463 FischerElektronik	R2	33	35.5	36
301415.019-01	SK120 FischerElektronik	R2	38	40.5	41

**Figure 1-8: CPC504-01/02 Module Dimensions with R2 Heatsink (8HP)****Figure 1-9: CPC504-03/04 Module Dimensions with R1 Heatsink and MIC588****Figure 1-10: CPC504-03/04 Module Dimensions with R2 Heatsink and MIC588**

*The appearance may vary for different versions of the module.*

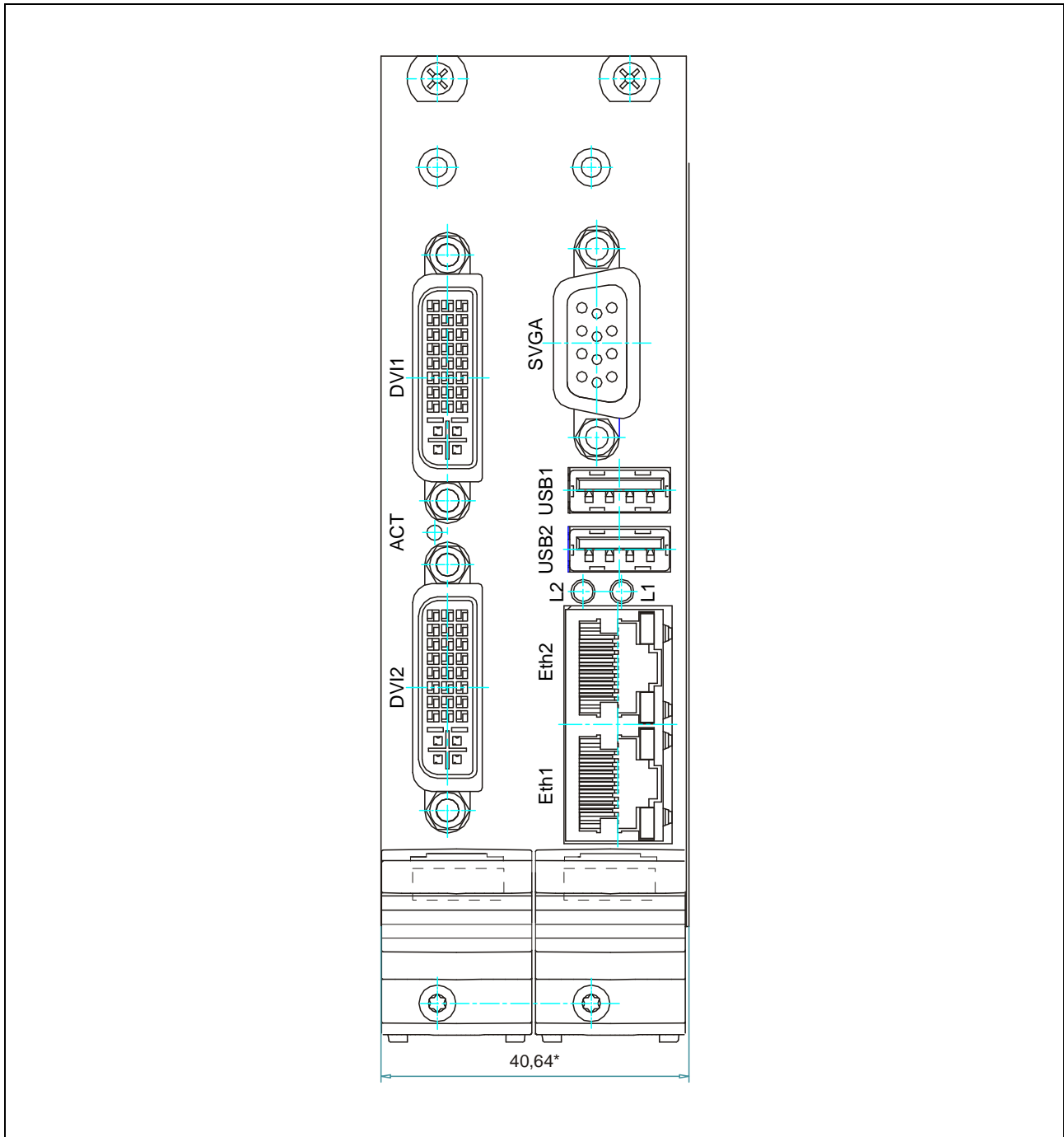
### 1.3.5 Front Panel

Figure 1-11: CPC504-01/02 4HP Front Panel



*The appearance may slightly differ for various versions of the module.*

Figure 1-12: CPC504-03/04 Front Panel



*The appearance may slightly differ for various versions of the module.*

The buttons of ejector handles are used to unlock the assembly. Moreover, the right button is a programmable switch that can be used to initialize the system manually.



## 1.4 Technical Characteristics

### 1.4.1 Processor, Memory and Chipset

#### CPU

CPC504 supports the following Intel processors:

Name	L2 Cache	Clock Speed	FSB Speed	TDP
Intel Celeron ULV 573	512 KB	1.00 GHz	533 MHz	10 W
Intel Core 2 Duo L7500	4 MB	1.6 GHz	800 MHz	17 W
Intel Core 2 Duo T7500	4 MB	2.2 GHz	800 MHz	35 W

#### System Memory

- Up to 4 GB of soldered DDR2 SDRAM, w/o ECC
- DDR2-667 standard (PC2-5300)
- I/O bus clock: 333 MHz
- Dual channel mode enabled

#### Chipset

##### GMCH: Intel® 82965GME

- Integrated dual-channel DDR2 memory controller
- FSB interface at 800 MHz
- Integrated high-performance graphics controller with analog and digital output
- Support for external graphics controller with PCI Express x16 interface

##### Intel® ICH8M I/O Controller Hub

- PCI Rev. 2.2 compliant with support for 33 MHz/32-bit PCI bus
- Configurable PCI Express interface
- Serial ATA II controller, 3 channels
- Integrated IDE controller Ultra ATA100, one channel
- USB 2.0 host interface, 10 ports
- Low Pin Count (LPC) interface
- HD-audio interface
- SPI bus support
- Integrated RTC with CMOS
- Power management controller with ACPI and APM support
- System Management Bus
- Firmware Hub (FWH) interface support
- Enhanced DMA controller, interrupt controller, and timer
- Additional timers

## 1.4.2 Interfaces

### CompactPCI Bus Interface

Compliant with CompactPCI Specification PICMG® 2.0 R3.0

- System master operation
- 32-bit / 33 MHz master interface
- 3.3V / 5.0V compatible
- Up to 7 bus master devices
- Individual clocks for PCI devices
- PCI-PCI bridge asynchronous mode support

### PCI Express

- Routed to Rear I/O module connector
- Configurable as one x4 or four x1

### Serial Ports

- Connectors on mezzanine or Rear I/O module
- Realized via LPC interface

### Parallel Port

- Connector on MIC584 mezzanine or Rear I/O module
- IEEE1284, ECP/EPP

### USB Interface

Five USB 2.0 ports:

- USB1 and USB2: two Type A connectors on the CPC504 front panel
- USB3 and USB4: routed to MIC584 via J2 connector
- USB5 available via Rear I/O

### Gigabit Ethernet

Two 10/100/1000 Mb/s Gigabit Ethernet interfaces based on the Intel 82574L GbE PCI Express bus controllers.

- Two RJ45 connectors on the front panel
- Switchable between front panel and Rear I/O
- Automatic mode recognition
- Automatic cabling configuration recognition
- Cabling requirement: Category 5, UTP, four-pair cabling

### Graphics

Built-in graphics controller

- High performance Intel® Graphics Media Accelerator (GMA)
- Video memory up to 384 MB shared with system
- CRT monitors with resolutions of up to 2048 x 1536, 32 bit at 75 Hz
- Dual SDVO support, available via two DVI-D connectors at MIC588 module
- Video output switchable between front panel and Rear I/O
- External graphics controller support via PCI-E x16

## HD Audio

- Realized on mezzanine (MIC584) or on Rear I/O module
- Line input/output (optional)
- Microphone input
- Headphones output
- 5.1 and 7.1 modes supported

## Keyboard and Mouse

- USB KB and MS can be directly connected to CPC504
- PS/2 port is available at MIC584 front panel, mouse and keyboard simultaneous connection is possible via Y-cable

## Secure Digital Socket

- Connected to internal USB 2.0 port
- Up to 16 GB cards supported

## Flash Disk

- Soldered NAND flash disk 4 GB (ver. -01 and -03)
- IDE interface (up to 50 MB/s)
- Software disconnectable
- Can be used as bootable disk

## FRAM

- 1 KB is used by the manufacturer
- 31 available to user

## FPGA

- Keyboard controller functionality
- LED indicators control
- Watchdog timer control

## SATA Interface

- Three ports: two connectors on mezzanine module, one – on Rear I/O
- SATA and SATA II modes supported

## Flash BIOS

- 8 Mb serial EEPROM with SPI interface
- In-system modification

### 1.4.3 Control and Monitoring

#### LED Indicators

System status:

- L1: Activity indicator
  - Yellow: SD memory card
  - Red: SATA or flash disks
- L2:
  - Startup process monitoring
  - Special system states indication
  - Programmable by user(see details in [LED Indicators](#) section)

Gigabit Ethernet status (1 and 2):

- Line (green): Line connected
- Act (green): Network activity

#### Programmable Switch

- Can be used for manual initialization of the system
- Integrated into the ejector handle

#### Thermal Management

Processor is protected from overheating by:

- Internal processor temperature control unit, which initiates CPU shut down
- Processor die temperature monitor
- Memory chips temperature monitor
- Custom designed heatsinks

#### Temperature Monitors

- LM87 hardware monitor is used for supervision of the on-die CPU temperature and the board surface temperature
- LM95235 for the memory chips temperature monitoring

#### Real Time Clock

- Built in ICH8M

#### Watchdog Timer

- Realized in FPGA
- Programmable timeout period
- Selectable NMI, IRQ, or Reset signals generation

## 1.4.4 General

### Mechanical

3U CompactPCI form factor

Dimensions: 130.4 × 212.5 × 20.32 mm (5.13" × 8.37" × 0.8")

Module Weight: 380 g max

### Power Supply

+5 V ±5%; +3.3 V ±5% (from CompactPCI connector)

See [Section 6.2](#) for details on power supply requirements

### Temperature Ranges

Operational:	CPC504-I	-40°C ... +85°C
	CPC504-C	0°C ... +70°C

Storage:		-55°C ... +85°C
----------	--	-----------------

### Humidity

0 to 80% RH, non-condensing

### Battery

3.0 V lithium battery for RTC in a battery holder.

Use Panasonic BR2032 or compatible

## 1.4.5 Software

### Software BIOS

Flash memory based enhanced Phoenix® BIOS has the following features:

- BIOS boot support for USB keyboards
- Software enable/disable function for the Rear I/O, Ethernet, and COM ports configuration
- Plug&Play capability
- Ethernet boot option
- Onboard peripherals enable/disable function
- CPU power management features
- Programmable handle switch function
- Programmable LED control
- FRAM enable option
- MIC584&MIC588 configuration options

### Operating Systems

Supported operating systems:

- FreeDOS, preinstalled
- Microsoft® Windows® XPe
- Linux® 2.6

## 1.5 Delivery Checklist

The CPC504 delivery set includes:

1. CPC504 processor module
2. PCI Express configuration jumper
3. Antistatic bag
4. Consumer carton box



**Note:**

Keep the antistatic bag and the original package at least until the warranty period is over. It can be used for future storage or warranty shipments.

## 1.6 System Expansion Modules

To expand system I/O capabilities Fastwel offers a number of interface modules. Each of these modules is available in two versions, differing in operating temperature range.

**Table 1-3: Interface Expansion Modules**

Name	Description	Connection
MIC584	Mezzanine kit interface module	Via J2 mezzanine connector
MIC588	Mezzanine DVI module	Via J1 mezzanine connector. Installed on CPC504-03/-04
RIO588*	Rear DVI module for MIC588	cPCI connector

(\*) *The module is developed on order.*

MIC584 is a mezzanine interface expansion module. It is designed to be installed on the top side of CPC504 processor module and is connected via J2 connector. An 1.8" SATA HDD or SSD can be installed on MIC584 using KIB584 adapter module.

MIC584 has the following interfaces and connectors:

- Six RS232 and RS485 serial ports – one D-Sub connector on the front panel (COM1) and four IDC connectors on board
- Two USB 2.0 ports (Type A front panel connectors)
- One LPT on-board header for connection of a PC-compatible printer or other devices with parallel interface
- Two SerialATA connectors on board
- Audio Interface, front panel sockets for connection of a microphone (Mic) and headphones (Phone) and Line In/Out headers onboard
- 6-pin PS/2 keyboard/mouse front panel connector
- Two LEDs on the front panel

MIC588 mezzanine interface expansion module is designed to be installed on the bottom side of CPC504 and connected to the processor module via J1 connector (versions -03 and -04). This module occupies the next slot to the left of CPC504 and is powered via the backplane. Additionally, they provide possibility to direct video output to the RIO588 rear expansion module.

The detailed description of expansion modules can be found in relevant sections of this Manual.

## 2 Detailed Description

### 2.1 Processor, Memory and Chipset

#### 2.1.1 Processor

CPC504 can be equipped with the following Intel processors:

Name	L2 Cache	Clock Speed	FSB Speed	TDP
Intel Celeron ULV 573	512 KB	1.0 GHz	533 MHz	10 W
Intel Core 2 Duo L7500	4 MB	1.6 GHz	800 MHz	17 W
Intel Core 2 Duo T7500	4 MB	2.2 GHz	800 MHz	35 W

Supported features of Core™ 2 Duo CPUs are:

- Intel® Core™ Microarchitecture
- Dual Execution Cores
- Intel® EM64T
- SSE2, SSE3, SSSE3
- Advanced Transfer Cache Architecture
- Intel® Dynamic Acceleration
- Intel® Thermal monitor with Adaptive Thermal Monitor 2 enhancement
- Manufactured on 65 nm process
- Enhanced Intel Speedstep® Technology
- Dynamic FSB Frequency Switching
- Intel® Virtualization Technology
- Execute Disable Bit

Intel® Celeron® ULV 573 processor offers low TDP and provides high performance to power dissipation ratio. Having single core, it has the same microarchitecture and supports virtually the same main features.

The CPU is soldered to provide excellent shock and vibration stability.

#### 2.1.2 System Memory

Total capacity of the soldered DDR2 SDRAM chips can be up to 4 GB. The installed memory is DDR2-667 (PC2-5300) compliant and supports PC SPD (Serial Presence Detect) Specification. Dual channel mode is supported.



### 2.1.3 Intel® Chipset

The chipset consists of the following devices:

- 82965GME Graphics and Memory Controller Hub (GMCH)
- ICH8M I/O Controller Hub

#### North Bridge

The 965GME GMCH provides interfaces with the CPU via Front Side Bus (FSB), with dual channel DDR2 SDRAM system memory, interface to high performance internal graphics controller or external graphics controller via x16 PCIe link. It also provides DMI interface to the ICH.

The internal graphics controller allows connection of analog and digital displays.

Power management features include ACPI 3.0 support and Dynamic FSB frequency switching.

#### South Bridge

The ICH8M (82801HBM) is a multifunctional I/O Controller Hub that provides interface to the 32-bit PCI Bus and configurable PCI Express bus, as well as to such PC interfaces as one UltraDMA100 IDE channel, three SATA II channels, ten USB 2.0 ports, internal real time clock with CMOS, power controller supporting ACPI and APM. Support for LPC interface, HD audio, and SPI is also provided.

## 2.2 Internal Peripherals

The following internal peripherals are available on the CPC504 module:

### 2.2.1 Timers

CPC504 is equipped with the following timers:

#### ■ RTC – Real-Time Clock

The ICH contains a MC146818A-compatible real-time clock. The RTC includes 256 bytes of battery-backed CMOS RAM. The RTC features include timekeeping with alarm function and 100-year calendar, as well as programmable periodic interrupt. A coin-cell battery powers the real-time clock and CMOS memory.

#### ■ Counters/Timers

Three 8254-type counters/timers integrated in ICH are available on the CPC504.

#### ■ Additional Timer

The ICH includes an additional programmable timer, which prevents system hang-ups during start-ups. After the first time-out period is over, it generates the SMI# signal, which starts the software hang-up recovery subroutine. If the second timeout ends, the "Reset" signal is issued to recover the system from the hardware hang-up state.

## ■ Watchdog Timer

The watchdog timer eliminates system hang-ups both during the start-up process (for example, in case of mistakes in BIOS, when the additional timer is not able to restart the system) and during normal operation. The timeout period is set in BIOS Setup program. On the expiry of the timeout period the watchdog timer issues the "Reset" signal or SMI or an interrupt. During start-up process watchdog timer monitors the BIOS code execution and resets the system in case of activation error. The instructions on watchdog timer programming can be found in the following subsections.

### 2.2.1.1 Watchdog Timer

Watchdog timer is realized in FPGA (XC3S250E) as a LPC device. Watchdog timer consists of 24-bit Counter register (Timer Current Value Register) decremented with frequency of 32.768 kHz and Initial value register (Timer Initial Value Register). On expiry of the timeout period either interrupt, or SMI, or Reset signal is generated. It is possible to set the timeout period from 0 to 512 seconds with increments of 30.52  $\mu$ s by changing the decimal value in BIOS Setup.

By default, without prior initialization, the watchdog timeout period is set to maximum that is 512 seconds. The equation below can be used to calculate the timeout  $T_{WD}$  in  $\mu$ s as a function of the decimal value in the Timer Initial Value Register ( $K_{WD}$ ):

$$T_{WD} [\mu s] = K_{WD} * 10^6 / 2^{15}$$

For example, decimal value "1" of  $K_{WD}$  (000001h) corresponds to the timeout of 30.52  $\mu$ s, and  $K_{WD} = 16777215$  (FFFFFFh) to 512 seconds.

Strobing of the watchdog timer is performed in one of the following ways:

- Writing any value in the Timer Current Value Register
- Writing any value in 80h port (this mode is enabled in Timer Init Register)
- Writing to or reading from two windows. The address is set in appropriate Window Base Address registers, the address mask is set in Windows 1&2 Address mask register, the mode is set in Timer Init Register. The Window size is from 1 to 16 bytes depending on the value in the Mask register.

### Access to Watchdog Registers

The unit's configuration is based on Plug-and-Play architecture. Access to watchdog registers is available via standard I/O registers (index and data) in configuration mode.

Port	Address	Function
CONFIG PORT	302h	Write
INDEX PORT	302h	Read/Write
DATA PORT	303h	Read/Write

### Configuration Mode

To enter the configuration mode write <46h><57h> key to CONFIG PORT. To exit the configuration mode write <57h><46h> key to CONFIG PORT. INDEX and DATA ports are available in configuration mode only.

## Watchdog Timer Programming

The procedures of watchdog programming is described below:

- Enter configuration mode

```
MOV  DX, 302H
MOV  AL, 46H
OUT  DX, AL
MOV  AL, 57H
OUT  DX, AL
```

- Write to LDN register a logic device number (watchdog timer has logical number 1)

```
MOV  DX, 302H
MOV  AL, 7
OUT  DX, AL
MOV  DX, 303H
MOV  AL, 1
OUT  DX, AL
```

- Watchdog timer registers are available for read and write now.  
For example, to read status register 3Eh and to write the value from it back:

```
MOV  DX, 302H
MOV  AL, 3EH
OUT  DX, AL
MOV  DX, 303H
IN   AL, DX
OUT  DX, AL
```

- To exit configuration mode:

```
MOV  DX, 302H
MOV  AL, 57H
OUT  DX, AL
MOV  AL, 46H
OUT  DX, AL
```

## Global Configuration Registers

Index	Type	Hard Reset	Configuration Register
7h	R/W	01h	Logical Device Number

### Logical Device Number register (index 7h)

Index = 7h		
Bit	Name	Description
7:0	LDN	Write/Read: Writing to this register selects logical device.

## Logical Device 1 Configuration Registers (Watchdog Timer)

Index	I/O Port Address	Type	Hard Reset	Configuration Register
30h	-	R/W		Activate
38h	Base+0	R/W		Timer current value [7:0]
39h	Base+1	R/W		Timer current value [15:8]
3ah	Base+2	R/W		Timer current value [23:16]
3bh	Base+3	R/W	00h	Timer initial value [7:0]
3ch	Base+4	R/W	40h	Timer initial value [15:8]
3dh	Base+5	R/W	00h	Timer initial value [23:16]
3eh	Base+6	R/W	00h	Status register
3fh	Base+7	R/W	03h	Control register
60h	-	R/W		Base[15:8] - I/O port base address bits [15:8]
61h	-	R/W		Base[7:3] - I/O port base address bits [7:3] Base[2:0] – should be 0;
70h	-	R/W	00h	Primary interrupt select
F0h	-	R/W	00h	Reserved
F1h	-	R/W	00h	Timer Init Register
F2h	-	R/W	00h	Window 1 base address bits [7:0]
F3h	-	R/W	00h	Window 1 base address bits [15:8]
F4h	-	R/W	00h	Window 2 base address bits [7:0]
F5h	-	R/W	00h	Window 2 base address bits [15:8]
F6h	-	R/W	FFh	Window 1 Mask bits [7:4] Window 2 Mask bits [3:0]

### Activate register

Index = 30h		
Bit	Name	Description
7:1	-	Not used
0	Activate	Write/Read: 1 – Current logical device enabled 0 – Current logical device disabled

**I/O port base address registers**

Index = 60h		
Bit	Name	Description
7:0	I/O_Base_Adress[15:8]	Write/Read: Current logical device base address bits 15:8
Index = 61h		
Bit	Name	Description
7:0	I/O_Base_Adress[7:0]	Write/Read: Current logical device base address bits 7:0

**Primary interrupt select register**

Index = 70h		
Bit	Name	Description
7:4	–	Not used
3:0	Interrupt_select	Write/Read: 00h – Interrupt disabled 01h – IRQ1 02h – SMI 03h – IRQ3 04h – IRQ4 05h – IRQ5 06h – IRQ6 07h – IRQ7 08h – IRQ8. Interrupt disabled 09h – IRQ9 0ah – IRQ10 0bh – IRQ11 0ch – IRQ12 0dh – IRQ13. Interrupt disabled 0eh – IRQ14. Interrupt disabled 0fh – IRQ15. Interrupt disabled

### Timer Init register

Index = F1h		
Bit	Name	Description
7:5	–	Not used
4	P80E	Write/Read: Counter reset on writing to 80h port 1 – Enabled 0 – Disabled
3	WND2_WR_EN	Write/Read: Counter reset on writing cycle to window 2 1 – Enabled 0 – Disabled
2	WND2_RD_EN	Write/Read: Counter reset on reading cycle from window 2 1 – Enabled 0 – Disabled
1	WND1_WR_EN	Write/Read: Counter reset on writing cycle to window 1 1 – Enabled 0 – Disabled
0	WND1_RD_EN	Write/Read: Counter reset on reading cycle from window 1 1 – Enabled 0 – Disabled

### Window 1 port base address registers

Index = F2h		
Bit	Name	Description
7:0	Window1_Base_Adress[7:0]	Write/Read: Bits 7:0 of Window 1 base address
Index = F3h		
Bit	Name	Description
7:0	Window1_Base_Adress[15:8]	Write/Read: Bits 15:8 of Window 1 base address

### Window 2 port base address registers

Index = F4h		
Bit	Name	Description
7:0	Window2_Base_Adress[7:0]	Write/Read: Bits 7:0 of Window 2 base address
Index = F5h		
Bit	Name	Description
7:0	Window2_Base_Adress[15:8]	Write/Read: Bits 15:8 of Window 2 base address

**Windows 1&2 address mask register**

Index = F6h		
Bit	Name	Description
7:4	Window1_MASK[3:0]	Write/Read: Bits 3:0 Window 1 address mask
3:0	Window2_MASK[3:0]	Write/Read: Bits 3:0 Window 2 address mask

**WDT Controller I/O Registers****Timer Current Value Register [23:0]**

Base+0h		
Bit	Name	Description
7:0	Timer_Current_Value[7:0]	Write/Read: Bits 7:0 of the current timer value
Base+1h		
Bit	Name	Description
7:0	Timer_Current_Value[15:8]	Write/Read: Bits 15:8 of the current timer value
Base+2h		
Bit	Name	Description
7:0	Timer_Current_Value[23:16]	Write/Read: Bits 23:16 of the current timer value

**Timer Initial Value Register [23:0]**

Base+3h		
Bit	Name	Description
7:0	Timer_Initial_Value[7:0]	Write/Read: Bits 7:0 of the initial timer value
Base+4h		
Bit	Name	Description
7:0	Timer_Initial_Value[15:8]	Write/Read: Bits 15:8 of the initial timer value
Base+5h		
Bit	Name	Description
7:0	Timer_Initial_Value[23:16]	Write/Read: Bits 23:16 of the initial timer value

**Status Register**

Base+6h		
Bit	Name	Description
7:3	–	Reserved
2	STM	Write/Read: Second timeout flag. It is set to “1”, if TMF=1 and RSTE=1. Cleared by writing “1” into this bit.
1	SME	Read: SMI enabled on timeout flag. It is set to “1”, if SMI mode is enabled in Primary interrupt select register (index 70h).
0	TMF	Write/Read: Timeout flag. It is set to “1” on expiry of the timeout. This flag enables interrupt generation. Cleared by writing “1” into this bit, or by writing to 80h port, or on access to windows 1 or 2 on condition that one of these modes is enabled.

**Control Register**

Base+7h		
Bit	Name	Description
7:3	–	Reserved
1	CNTE	Write/Read: Writing “1” enables watchdog countdown.
0	RSTE	Write/Read: Writing “1” enables Reset on timeout.

**2.2.2 Battery**

The CPC504 utilizes a 3.0 V lithium battery for the RTC and CMOS memory backup. Use Panasonic BR2032 or compatible. Batteryless operation is possible with no RTC function.

**2.2.3 Local SMBus Devices**

The CPC504 incorporates a System Management Bus to access several system monitoring and control devices via a two-wire I<sup>2</sup>C™ bus interface. The following table presents functions and addresses of onboard SMBus devices.

**Table 2-1: SMBus Devices**

No	SMB Address	Device
1	0D2H	SLG8SP533V System clock generator
2	0A0H and 0A2H	SPD EEPROM module
3	5CH	LM87 PCB & CPU temperature sensor
4	4CH	LM95235 RAM temperature sensor

Upon request, temperature monitors can report information on temperatures of system components to system control facilities ensuring safe operation.



## 2.2.4 Flash Memory

### 2.2.4.1 NAND Flash

The CPC504 (versions -01 and -03) is equipped with soldered NAND flash memory modules with IDE interface (up to 50 MB/s) having total capacity of up to 4 GB for storing user programs and data. It can be used as a boot disk.

### 2.2.4.2 Secure Digital Socket

The CPC504 has a standard socket for SD cards connected to an internal USB 2.0 port. Maximum capacity of SD cards is 16 GB.

### 2.2.4.3 FRAM Emergency Storage for User Data

Fast serial FRAM (32 KB) is installed on the module. 1 KB is used by manufacturer, 31 KB is available for storage of critical user data in case of power supply failure. FRAM device registers and programming is described below.

#### FRAM Registers (Logical device 3)

Index	I/O Port Address	Type	Hard Reset	Configuration Register
30h	-	R/W		Activate
	Base+0	R/W	00h	FRAM address value [7:0]
	Base+1	R/W	00h	FRAM address value [14:8]
	Base+2	R/W	00h	FRAM data value [7:0]
	Base+3	R/W	00h	FRAM Control register [7:1] – reserved [0] – autoincrement mode
60h	-	R/W		Base[15:8] - I/O port base address bits [15:8]
61h	-	R/W		Base[7:3] - I/O port base address bits [7:3] Base[2:0] – must be 0

To work with FRAM it is necessary to set the base address for the device (LDN=3) and activate it the same way it is done for the watchdog timer. Subsequent operation is performed in I/O area in relation to the specified base address. Bit <0> of the Control register (Base+3) enables the address autoincrement mode for reading from/writing to the Data register (Base+2).

#### FRAM Programming

The procedures of FRAM programming is described below:

- Enter configuration mode:

```
MOV  DX, 302H
MOV  AL, 46H
OUT  DX, AL
MOV  AL, 57H
OUT  DX, AL
```

- Write to LDN register a logic device number (FRAM has logical number 3):

```
MOV DX, 302H
MOV AL, 7
OUT DX, AL
MOV DX, 303H
MOV AL, 3
OUT DX, AL
```

- Set base address for the device in I/O area (for example, 310h):

```
MOV DX, 302H
MOV AL, 60H
OUT DX, AL
MOV DX, 303H
MOV AL, 3H
OUT DX, AL
MOV DX, 302H
MOV AL, 61H
OUT DX, AL
MOV DX, 303H
MOV AL, 10H
OUT DX, AL
```

- Activate the device:

```
MOV DX, 302H
MOV AL, 30H
OUT DX, AL
MOV DX, 303H
MOV AL, 1H
OUT DX, AL
```

- To exit configuration mode:

```
MOV DX, 302H
MOV AL, 57H
OUT DX, AL
MOV AL, 46H
OUT DX, AL
```

Further operations with FRAM are performed in I/O area at addresses 310h-313h.

- Write data byte (32h) to FRAM address 144h:

```
MOV DX, 310H
MOV AL, 44H
OUT DX, AL
MOV DX, 311H
MOV AL, 01H
OUT DX, AL
MOV DX, 312h
MOV AL, 32h
OUT DX, AL
```

- Reading data byte from FRAM address 101h:

```
MOV  DX, 310H
MOV  AL, 01H
OUT  DX, AL
MOV  DX, 311H
MOV  AL, 10H
OUT  DX, AL
MOV  DX, 312h
IN   AL, DX
```

## 2.3 Module Interfaces

### 2.3.1 CompactPCI Bus Connectors

Figure 2-1: CompactPCI Connectors J1 and J2 →

The CPC504 is designed for a CompactPCI bus architecture, but it utilizes only two of standard CompactPCI connectors – J1 and J2. The CompactPCI standard is electrically identical to the PCI local bus. However, these systems are improved to support multiple slots and to operate in harsh industrial environments.

J1 standard CompactPCI connector is marked as J6 on board, J2 is marked as J3.

#### 2.3.1.1 CompactPCI Connector Color Coding

Guide lugs on CompactPCI connectors serve to ensure a correct mating of connectors. A proper mating is guaranteed also by the use of color coded keys for 3.3V and 5V operation. Color coded keys prevent accidental installation of a 5V module into a 3.3V slot. CompactPCI backplane connectors' keying depends always on the signaling (VIO) level. On universal backplanes supporting both signalling levels, VIO level is selected by a jumper on the backplane.

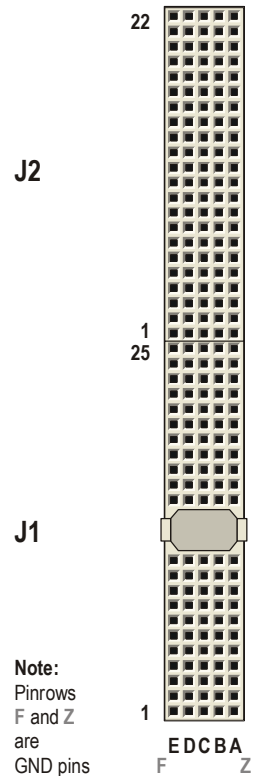
CPC504 is a universal module with 3.3V or 5V signalling voltage level.

Coding key colors are described below:

Table 2-2: CompactPCI Connector Coding Colors

Voltage Level	Key Color
3.3 V	Cadmium Yellow
5 V	Brilliant Blue
Universal module (5V and 3.3V)	None

CompactPCI connector pinouts appear on the following pages.



### 2.3.1.2 CompactPCI Connectors J1 and J2 Pinouts

CPC504 is equipped with two 2x2 mm pitch female CompactPCI bus connectors – J1 (J6) and J2 (J3).

**Table 2-3: CompactPCI Bus Connector J1 (J6) System Slot Pinout**

Pin	Z	A	B	C	D	E	F				
25	GND	5V	REQ64#	ENUM#	3.3V	5V	GND				
24	GND	AD[1]	5V	LNG_VIO	AD[0]	ACK64#	GND				
23	GND	3.3V	AD[4]	AD[3]	LNG_5V	AD[2]	GND				
22	GND	AD[7]	GND	LNG_3.3V	AD[6]	AD[5]	GND				
21	GND	3.3V	AD[9]	AD[8]	M66EN	C/BE[0]#	GND				
20	GND	AD[12]	GND	VIO	AD[11]	AD[10]	GND				
19	GND	3.3V	AD[15]	AD[14]	LNG_GND	AD[13]	GND				
18	GND	SERR#	GND	3.3V	PAR	C/BE[1]#	GND				
17	GND	3.3V	IPMB_SCL	IPMB_SDA	LNG_GND	PERR#	GND				
16	GND	DEVSEL#	GND	VIO	STOP#	LOCK#	GND				
15	GND	3.3V	FRAME#	IRDY#	SHRT_GND	TRDY#	GND				
14	GND	Key Area						GND			
13	GND										GND
12	GND										GND
11	GND	AD[18]	AD[17]	AD[16]	LNG_GND	C/BE[2]#	GND				
10	GND	AD[21]	GND	3.3V	AD[20]	AD[19]	GND				
9	GND	C/BE[3]#	SHRT_GND	AD[23]	LNG_GND	AD[22]	GND				
8	GND	AD[26]	GND	VIO	AD[25]	AD[24]	GND				
7	GND	AD[30]	AD[29]	AD[28]	LNG_GND	AD[27]	GND				
6	GND	REQ0#	GND	LNG_3.3V	CLK0	AD[31]	GND				
5	GND	BRSVP1A5	BRSVP1B5	RST#	LNG_GND	GNT0#	GND				
4	GND	IPMB_PWR	HEALTHY#	LNG_VIO	INTP	INTS	GND				
3	GND	INTA#	INTB#	INTC#	LNG_5V	INTD#	GND				
2	GND	TCK	5V	TMS	TDO	TDI	GND				
1	GND	5V	-12V	TRST#	+12V	5V	GND				

Table 2-4: 32-bit CompactPCI Bus Connector J2 (J3) System Slot Pinout

Pin	Z	A	B	C	D	E	F
22	GND	GA4	GA3	GA2	GA1	GA0	GND
21	GND	CLK6	GND	+3.3V	AC_SDIN	AC_BIT_CLK	GND
20	GND	CLK5	GND	AC_SDOUT	AC_RST#	AC_SYNC	GND
19	GND	GND	GND	BP(I/O)	BP(I/O)	BP(I/O)	GND
18	GND	GBE2_MD3N	GBE2_MD1N	GND	PCI_RST#	PCI_SERIRQ	GND
17	GND	GBE2_MD3P	GBE2_MD1P	PRST#	REQ6#	GNT6#	GND
16	GND	GBE2_MD2N	GBE2_MD0N	DEG#	GND	PCI_CLK	GND
15	GND	GBE2_MD2P	GBE2_MD0P	FAL#	REQ5#	GNT5#	GND
14	GND	VGA_BLUE	VGA_HSYNC	GBE1_MD2N	VGA_VSYNC	GBE1_MD0N	GND
13	GND	VGA_GREEN	GBE1_MD3N	GBE1_MD2P	GBE1_MD1N	GBE1_MD0P	GND
12	GND	VGA_RED	GBE1_MD3P	VGA_DDCCLK	GBE1_MD1P	VGA_DDCDAT	GND
11	GND	USB_DATA#	SATA2_RXN	+5V	+5V	SMB_DATA	GND
10	GND	USB_DATA	SATA2_RXP	SATA2_TXN	SMB_CLK	GND	GND
9	GND	LPC_LAD3	LPC_LFRAME#	SATA2_TXP	GND	PE_CLK_N	GND
8	GND	LPC_LAD2	PE4_TN	GND	PE4_RN	PE_CLK_P	GND
7	GND	LPC_LAD1	PE4_TP	PE3_TN	PE4_RP	PE3_RN	GND
6	GND	LPC_LAD0	PE2_TN	PE3_TP	PE2_RN	PE3_RP	GND
5	GND	LPC_LDRQ	PE2_TP	PE1_TN	PE2_RP	PE1_RN	GND
4	GND	V(I/O)	GND	PE1_TP	GND	PE1_RP	GND
3	GND	CLK4	GND	GNT3#	REQ4#	GNT4#	GND
2	GND	CLK2	CLK3	SYSEN#	GNT2#	REQ3#	GND
1	GND	CLK1	GND	REQ1#	GNT1#	REQ2#	GND

## 2.3.2 Connectors for Mezzanine Modules

A number of interface expansion modules are used to enhance I/O capabilities of CPC504. MIC584 mezzanine module is installed on the top side (to the right) of CPC504 processor module; 60-contact J2 high speed connector socket is used for connection of MIC584.

MIC588 mezzanine module is installed on the bottom side (to the left) of the CPC504 versions -03 and -04 and occupies the backplane connector next to CPC504; 80-contact J1 high-speed differential type connector socket is used for connection. The pinout of J1 connector is not described in this document, since MIC588 and CPC504-03/-04 are supplied bodily.

Figure 2-2: J2 Expansion Connector for MIC584 Mezzanine Module

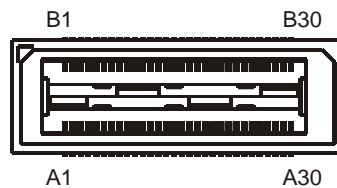


Table 2-5: Pinout of J2 Connector for MIC584 Mezzanine Module

Contact	Signal	Contact	Signal
A1	+5V	B1	+5V
A2	+5V	B2	+5V
A3	USB_PN0	B3	USB_PN1
A4	USB_PP0	B4	USB_PP1
A5	GND	B5	GND
A6	SATA_TXN0	B6	SATA_RXN0
A7	SATA_TXP0	B7	SATA_RXP0
A8	GND	B8	GND
A9	SATA_TXN1	B9	SATA_RXN1
A10	SATA_TXP1	B10	SATA_RXP1
A11	GND	B11	GND
A12	AZ_BITCLK	B12	LPC_AD0
A13	GND	B13	LPC_AD1
A14	AZ_SYNC	B14	LPC_AD2
A15	AZ_RST#	B15	LPC_AD3
A16	AZ_SDIN	B16	LPC_FRAME#
A17	AZ_SDOOUT	B17	GND
A18	+3.3V	B18	SERIRQ
A19	KBRST#	B19	+3.3V
A20	A20GATE	B20	DRQ0#
A21	+3.3V	B21	+3.3V
A22	PLT_RST#	B22	SMB_CLK
A23	GND	B23	SMB_DATA
A24	CLK_33MHz	B24	GND
A25	GND	B25	USB_OC#0
A26	CLK_14MHz	B26	USB_OC#1
A27	GND	B27	+3.3VA
A28	CLK_32kHz	B28	INIT_3V3
A29	GND	B29	BIOS_DIS#
A30	+5VA	B30	+5VA

### 2.3.3 Keyboard/Mouse Interface

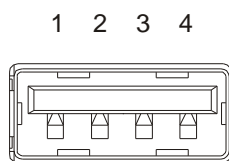
A keyboard and a mouse can be connected to CPC504 using front panel USB sockets. Moreover, PS/2 mouse and keyboard can be connected to a standard 6-contact MiniDIN connector on MIC584 front panel. Mouse and keyboard can be connected simultaneously using Y-cable.

CPC504 includes 8042-compatible keyboard controller emulator realized on FPGA. This is necessary for correct operation of supported operating systems when CPC504 is used without MIC584.

### 2.3.4 USB Interfaces

The CPC504 supports five USB 2.0 ports. Two ports (USB1 and USB2) are available on CPC504 front panel via two Type A connectors. Two ports (USB3 and USB4) are routed to J2 connector and are available at MIC584 mezzanine module. One more port (USB5) is routed to CompactPCI connector to be used via a rear I/O module.

Figure 2-3: USB1 (J22) и USB2 (J16) Sockets



All ports support high-speed, full-speed, and low-speed operation. Hi-speed USB 2.0 supports data transfer rate of up to 480 Mb/s. One USB device may be connected to each port. To connect more than five USB devices use an external hub.

The USB power supply is protected by a self-resettable 500 mA fuse.

Table 2-6: USB1 and USB2 Pinouts (CPC504 Front Panel)

Pin Number	Signal	Function	In/Out
1	VCC	VCC signal	–
2	UV0-	Differential USB-	–
3	UV0+	Differential USB+	–
4	GND	GND signal	–



## 2.3.5 Graphics Controller

A highly integrated 2D/3D graphics accelerator is included in the 965GME chipset. The internal graphics controller provides interfaces to a standard analog monitor (SVGA connector on CPC504 front panel) or/and to a digital displays. External video adapters with PCI Express x16 interface are supported.

Integrated 2D/3D Graphics features:

- 2D accelerator
- Up to 384 MB video memory shared with system
- Support for RGB monitors with resolutions up to 2048×1536, 32 bit at 75 Hz
- Dual DVI support, possibility to switch graphics output to rear panel
- Support for external video adapters with PCI-E x16 interface
- Support for DirectX 10.0, Open GL 2.0, Shader Model 4.0:
  - Core frequency up to 333 MHz;
  - Rendering frequency up to 500 MHz

### 2.3.5.1 DVM Technology

The 965GME chipset supports the Dynamic Video Memory Technology (DVMT). This technology provides use of all available memory in the most efficient way for maximum graphics performance. DVMT dynamically responds to requests from applications allocating the required amount of video memory. The Intel® 965GME graphics driver is allowed to request up to 384 MB of system memory. When not needed by the graphics subsystem, the memory is freed up for other applications. Thus, memory usage is balanced for optimal graphics and system memory performance.

To support legacy VGA devices the internal video-controller needs at least 1 MB of system memory. Thus, the reported system memory size is always 1 MB less than available amount of physical memory.

### 2.3.5.2 Supported Resolutions

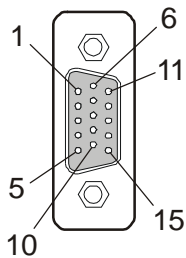
The integrated 400 MHz RAMDAC of the 965GME chipset allows direct connection of a progressive scan analog monitor with a resolution of up to 2048 × 1536 at 75 Hz. The supported resolution depends on the color depth and on the vertical scanning frequency, as illustrated in the table below.

Table 2-7: Partial List of Supported Display Modes

Display Mode	Color Resolution vs. Vertical Frequency											
	8-bit Indexed				16-bit				32-bit			
	60	75	85	100	60	75	85	100	60	75	85	100
640 × 480	x	x	x	x	x	x	x	x	x	x	x	x
800 × 600	x	x	x	x	x	x	x	x	x	x	x	x
1024 × 768	x	x	x	x	x	x	x	x	x	x	x	x
1280 × 1024	x	x	x	x	x	x	x	x	x	x	x	x
1600 × 1200	x	x	x	x	x	x	x	x	x	x	x	x
1920 × 1440	x	x	x		x	x	x		x	x	x	
2048 × 1536	x	x			x	x			x	x		

### 2.3.5.3 CRT Interface and Connector

Figure 2-4: SVGA (J45) Front Panel Connector



The 15-pin female D-Sub connector (J45) on CPC504 front panel is used to connect a CRT monitor to the CPC504 module.

Its pinout is in the table below.

Table 2-8: SVGA (J45) Front Panel Connector Pinout

Pin Number	Signal	Function	In/Out
1	Red	Red video signal output	Out
2	Green	Green video signal output	Out
3	Blue	Blue video signal output	Out
9	VCC	Power +5V DC 200 mA	Out
12	DDCdata	I <sup>2</sup> C™ data	In/Out
13	Hsync	Horizontal sync.	TTL out
14	Vsync	Vertical sync.	TTL out
15	DDCclk	I <sup>2</sup> C™ clock	Out
5, 6, 7, 8, 10	GND	Signal ground	–
4, 11	–	Free (reserved)	–

### 2.3.6 Serial Interfaces (RS232 and RS485)

Serial interfaces are available only on MIC584 interface expansion module. There are six serial ports available via MIC584 connectors:

- COM1 – RS232, 9-pin D-Sub front panel connector;
- COM2-COM4 – RS232, three IDC2-10 onboard connectors (XP11-XP13);
- COM5, COM6 – RS485, one IDC2-10 onboard connector (XP7).

All COM ports are fully compatible with the 16C550 controller and include a complete set of handshaking and modem control signals, maskable interrupt generation and data transfer of up to 460.8 Kb/s.

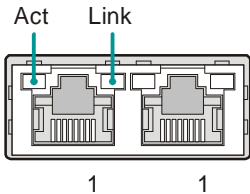
### 2.3.7 Parallel Port Interface

Standard parallel port (IEEE1284, SPP/ECP/EPP) is available only on MIC584 mezzanine module.

### 2.3.8 Gigabit Ethernet

The CPC504 board includes two 10Base-T/100Base-TX/1000Base-T Ethernet ports based on Intel® 82574L Gigabit Ethernet PCI-E bus controllers. The Intel® 82574L Gigabit Ethernet controller architecture combines high performance and low power consumption. The controller's features include independent transmit and receive queues to limit PCI-E bus traffic, and a PCI-E interface providing efficient bus utilization by increased use of bursts.

Figure 2-5: Ethernet Connectors



Two RJ45 Gigabit Ethernet connectors are located on CPC504 front panel (J24).

The interfaces provide auto-detection and switching between 10Base-T, 100Base-TX and 1000Base-T operation modes.

Each of the two Ethernet channels may be software switched to rear I/O to provide system flexibility.

Table 2-9: Gigabit Ethernet Connectors Pinouts

Pin	10Base-T		100Base-TX		1000Base-T	
	I/O	Signal	I/O	Signal	I/O	Signal
1	O	TX+	O	TX+	I/O	BI_DA+
2	O	TX-	O	TX-	I/O	BI_DA-
3	I	RX+	I	RX+	I/O	BI_DB+
4	-	-	-	-	I/O	BI_DC+
5	-	-	-	-	I/O	BI_DC-
6	I	RX-	I	RX-	I/O	BI_DB-
7	-	-	-	-	I/O	BI_DD+
8	-	-	-	-	I/O	BI_DD-

MDI / Standard Ethernet Cable

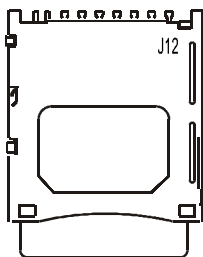
## Integrated Ethernet LEDs

Line (green): This LED indicates network connection. The LED lights up when the line is connected.

Act (green): this LED monitors network activity. The LED lights up when network packets are sent or received through the RJ45 port. When this LED is not lit, it means that the computer is not sending or receiving network data.

## 2.3.9 Socket for Secure Digital Card

Figure 2-6: SD Card Socket



To enable usage of SD memory cards CPC504 has a Secure Digital card socket (J12) on board.

SD interface is connected to an internal USB 2.0 port via SMSC USB2241 controller. SD cards with maximum capacity of 16 GB are supported.

## 2.3.10 LED Indicators

Two LED indicators L1 and L2 are located on the CPC504 front panel.

Table 2-10: L1 and L2 Front Panel Indicators

Name	Purpose	Color	Function
L1	Activity indicator	Yellow	SD memory card activity
		Red	SATA or Flash drive activity
L2	CPC504 boot process monitoring	Green, fast blinking (8 Hz)	The module is powered. The system is activated
		Green, slowly blinking (1 Hz)	POST (Power-On Self Test) in process
		Green, steady light	OS is being loaded
		Red, steady light	Activation error (wrong slot, incomplete insertion of the module, power supply failure)
	System state indication	Red, fast blinking (8 Hz)	Clear CMOS mode activated, pending Programmable switch release
		Orange, steady light	S5 (soft off) mode. The active mode is enabled by momentary pressing on Programmable switch.
		Orange, slowly blinking (0.5 Hz)	S3 (Suspend-To-RAM) mode. The active mode is enabled by momentary pressing on Programmable switch.
Programmed by user			

After initialization and OS loading, L2 indicator can be used as programmable LED. L2 modes programming is described below.

### 2.3.10.1 L2 Indicator Configuration and Control Registers

Table 2-11: L2 Indicator Configuration and Control Registers

Index	I/O Port Address	Type	Hard Reset	Configuration Register
30h	-	R/W	00h	Activate. Bit[0] to «1» – LED module is active.
-	Base+0	R/W	01h	LED data register [3:0]. The rest bits are nonsignificant; are read as «0».
60h	-	R/W		Base[15:8] - I/O port base address bits[15:8]
61h	-	R/W		Base[7:0] - I/O port base address bits[7:0]

To work with L2 indicator it is necessary to set the base address for the device (LDN=5) and activate it as it is done for the watchdog timer or FRAM module. L2 indicator is controlled via LED register. Subsequent operation is performed in I/O area in relation to the specified base address.

### 2.3.10.2 LED Register Initialization

To initialize the register follow the following procedure:

- Enter configuration mode:

```
MOV DX, 302H
MOV AL, 46H
OUT DX, AL
MOV AL, 57H
OUT DX, AL
```

- Write to LDN register a logic device number (LED register has logical number 5):

```
MOV DX, 302H
MOV AL, 7
OUT DX, AL
MOV DX, 303H
MOV AL, 5
OUT DX, AL
```

- Set base address for the device in I/O area (for example, 31dh):

```
MOV DX, 302H
MOV AL, 60H
OUT DX, AL
MOV DX, 303H
MOV AL, 3H
OUT DX, AL
MOV DX, 302H
MOV AL, 61H
OUT DX, AL
MOV DX, 303H
MOV AL, 1dH
OUT DX, AL
```

- Activate the device:

```
MOV  DX, 302H
MOV  AL, 30H
OUT  DX, AL
MOV  DX, 303H
MOV  AL, 1H
OUT  DX, AL
```

- To exit configuration mode:

```
MOV  DX, 302H
MOV  AL, 57H
OUT  DX, AL
MOV  AL, 46H
OUT  DX, AL
```

### 2.3.10.3 LED Register Bits

Table 2-12: LED Control Register Bits

Bit7	Bit6	Bit5	Bit4	Bit3	Bit2	Bit1	Bit0
Reserve bits are read as "0".				Red LED Bit1	Red LED Bit0	Green LED Bit1	Green LED Bit0

L2 LED indicator consists of two independent red and green LEDs. Thus, it can glow green, red or orange (red and green are both on). Each LED is independently controlled via the LED register bits. Operation mode for each LED is set by values in two bits as shown in the table below.

Table 2-13: L2 LED Operation Modes

Bit1	Bit0	Operation Mode
0	0	LED is off
0	1	Fast blinking (8 Hz)
1	0	Slow blinking (1 Hz)
1	1	Steady light

## 3 Installation

The CPC504 is easy to install. However, it is necessary to follow the procedures and safety regulations below to install the module correctly without damage to the hardware, or harm to personnel.

The installation of the peripheral drivers is described in the accompanying information files. For details on installation of an operating system, please refer to the relevant software documentation.

### 3.1 Safety Regulations

The following safety regulations must be observed when installing or operating the CPC504. Fastwel assumes no responsibility for any damage resulting from infringement of these rules.



#### Warning!

When handling or operating the module, special attention should be paid to the heatsink, because it can get very hot during operation. Do not touch the heatsink when installing or removing the module.

Moreover, the module should not be placed on any surface or in any kind of package until the module and its heatsink have cooled down to ambient temperature.



#### Caution!

If your module does not allow hotswapping, switch off the system power before installing the module in a free slot. Disregarding this requirement could be harmful for your life or health and can damage the module or entire system.



#### ESD Sensitive Equipment!

This product comprises electrostatically sensitive components. Please follow the ESD safety instructions to ensure module's operability and reliability:

- Use grounding equipment, if working at an anti-static workbench. Otherwise, discharge yourself and the tools in use before touching the sensitive equipment.
- Try to avoid touching contacts, leads and components.

Extra caution should be taken in cold and dry weather.

## 3.2 Installation Procedure

To install CPC504 in a system, follow the instructions below.

1. Keep to the safety regulations of the Section 3.1 when performing the following operations.



### Warning!

Failure to accomplish the following instruction may damage the module or result in incorrect system operation.

2. Ensure that the module configuration corresponds to the application requirements before installing. For information regarding the configuration of the CPC504, refer to [Chapter 4](#). For the installation of CPC504 specific peripheral devices and I/O devices refer to the appropriate sections in [Chapter 3](#). For details on installation of expansion modules, refer to respective sections of this document.
3. To install the CPC504:
  1. Make sure that no power is connected to the system.
  2. Avoiding contact with other modules of the system, carefully insert the module into the chosen slot until it contacts the backplane connectors. Do not apply force pushing the module into the backplane connectors.
  3. Using the front panel ejector handle, engage the module with the backplane. The module is completely engaged, when the ejector handle is locked. For versions -03 and -04 ensure simultaneous locking of both handles.
  4. Fix the module with the front panel retaining screws.
  5. Connect the required external interfacing cables to the module's connectors and make sure that the module and all connected cables are properly fixed.

The CPC504 is now ready for operation. Please, refer to appropriate software, application, and system manuals to get further instructions.

## 3.3 Removal Procedure

To remove the module from the system case do the following:

1. When performing the next actions, keep to safety regulations of the [Section 3.1](#). Pay special attention to the temperature of the heatsink!
2. Ensure that the system power is switched off before proceeding.
3. Disconnect all cables that may be connected to the module.
4. Unscrew the front panel retaining screws.
5. Unlock the module ejection handle(s) by pressing the integrated button(s), and then press on the handle(s) until the module connectors are disconnected from the backplane.
6. Carefully pull the module out of the slot. Do not touch the heatsink, since it can get very hot during operation.
7. Dispose of the module at your discretion. The module should not be placed on any surface or in any form of package until the board and the heatsink have cooled down to room temperature.



## 3.4 Peripheral Devices Installation

A lot of peripheral devices can be connected to the CPC504. Their installation procedures differ significantly. Therefore the following sections provide mainly general guidelines regarding installation of peripheral devices.

### 3.4.1 USB Devices Installation

The CPC504 can accept Plug&Play connection of USB 2.0 computer peripheral devices (printers, keyboards, mice, etc.) All USB devices may be connected or disconnected while the host power is on.

### 3.4.2 Secure Digital Cards Installation

SD socket of CPC504 (J12) supports SD cards with operating voltage of 3.3 V.



**Note:**

SD cards may be connected or disconnected while the system power is on.

Carefully slide in the correctly oriented card and gently press to engage the contacts completely. Please remember that the heatsink may be hot after operation.



**Note:**

It is recommended to use SD cards, which has been initialized and formatted in this module.

### 3.4.3 Battery Replacement

The lithium battery must be replaced with Panasonic BR2032 or a battery with similar characteristics.

The expected life of a 190 mAh battery in case of operation for 8 hours a day at 30°C is about 5 years. However, this typical value may vary because battery life depends on the operating temperature and the shutdown time of the system in which the battery is installed.



**Note...**

It is recommended to replace the battery after approximately 4 years to be sure it is operational.

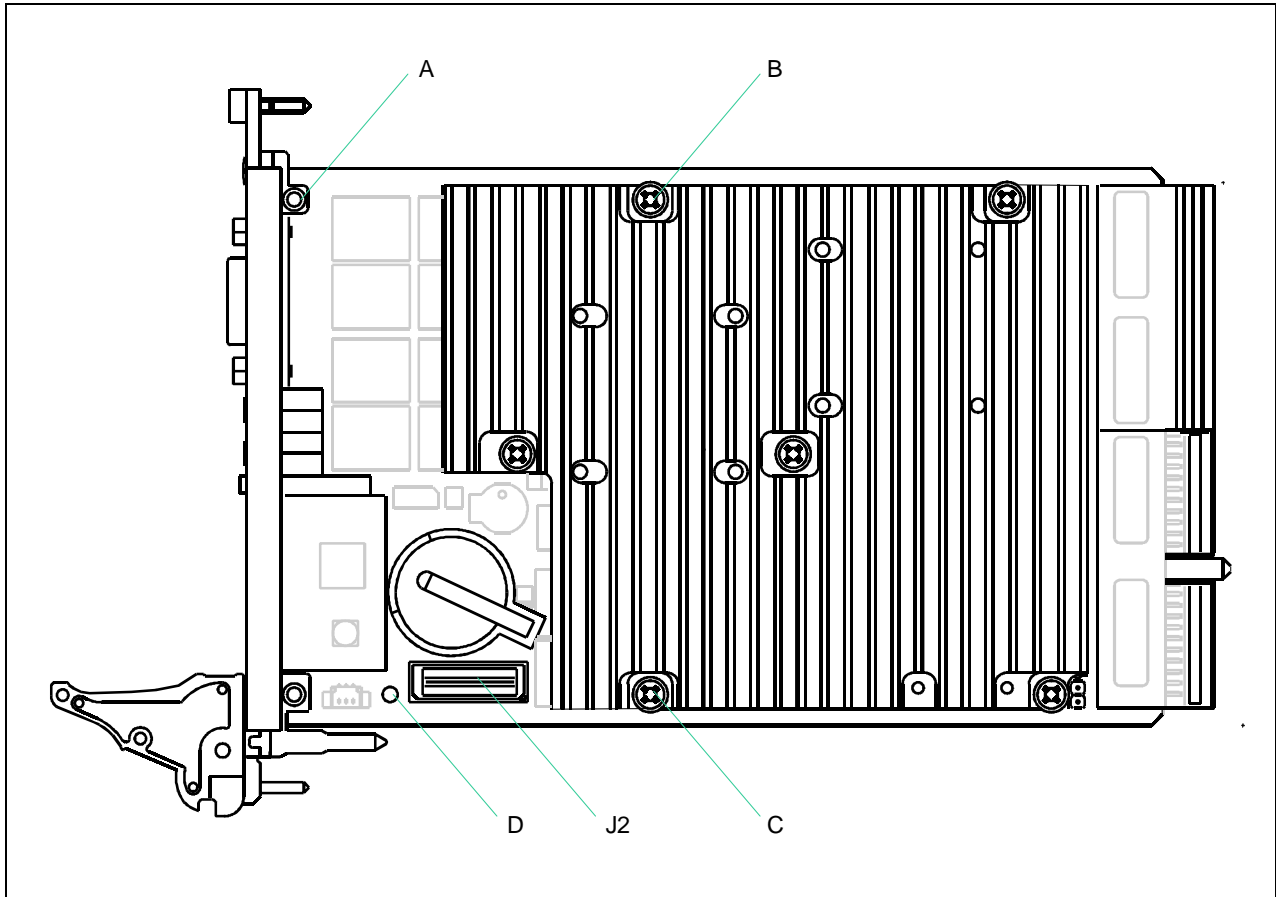


**Important:**

Replacing the battery, make sure the polarity is correct ("+" up).  
Dispose of used batteries according to the local regulations.

### 3.5 Installation of MIC584 Mezzanine Expansion Module

Figure 3-1: Fixing of MIC584 on CPC504



To install MIC584 mezzanine expansion module on CPC504 do the following:

1. Unscrew the B and C screws fixing the heatsink.
2. Install standoffs into A, B, C, and D openings.
3. Install MIC584 module engaging its XS6 connector with J2 connector of CPC504 and fix with screws at positions A, B, C, and D.



The details on connection of external devices to MIC584 module can be found in [Section 7](#) of this manual.

## 4 Configuration

### 4.1 PCI Express Operation Modes

J18 jumper located on the top side of the CPC504 module is used for switching between two PCI Express operation modes – one x4 link or four x1.

Table 4-1: PCI Express Operation Mode Selection

J18	Contacts	PCI Express Lanes Configuration
	Closed	One x4
	Open	Four x1

### 4.2 Clear CMOS

If the system is not booted (for example, due to incorrect BIOS settings), it is possible to clear BIOS Setup parameters stored in CMOS memory using Programmable switch. To clear CMOS memory, follow the procedure below:

1. Switch power off.
2. Press the button «Programmable switch» on the ejector handle and slightly open the ejector handle but do not move the module out of its slot.
3. Switch power on.
4. Wait until L2 red LED starts blinking fast and move the ejector handle back to the locked position by lifting it until the click.
5. Start BIOS Setup utility (F2) to configure the system.

## 5 Phoenix® BIOS Setup

The Phoenix® BIOS in your SBC is an adapted version of a standard BIOS for IBM PC AT-compatible personal computers equipped with Intel®x86 and compatible processors. The BIOS provides low-level support for the central processing, memory, and I/O system units.

With the help of BIOS Setup program, you can modify the BIOS configuration parameters and control the special features of your module. The Setup program is started by pressing the F2 key and offers a convenient menu interface to modify basic system configuration settings and switching between the subsystems operation modes. These settings are stored in a dedicated battery-backed memory, CMOS RAM, that keeps the information when the power is switched off. For increased security, the CMOS data and some of the service parameters are stored also in a nonvolatile serial EEPROM memory. This allows to restore the critical data in emergency cases after battery failure.

### 5.1 Boot Details

#### 5.1.1 Booting without a Monitor, Keyboard or Mouse

To boot without a monitor, keyboard or mouse set the item "POST Errors" to "Disabled" at the page "Main" in PhoenixBIOS Setup program. This setting is a default one.



#### Note!

If the module was booted without a connected monitor, the display will be empty, even if a monitor is connected later during operation. To get the correct display output it is necessary to reboot the module with a connected monitor. This is an Intel VideoBIOS particularity.

#### 5.1.2 Booting from USB

To boot from a device connected to USB:

- Connect the device to boot from to a USB port. The appropriate USB controller should be enabled;
- Enter the PhoenixBIOS Setup program;
- Find this USB device at the "Boot" page and use «+» «-» buttons to move it in order to change its boot priority;
- Save changes and reboot the module.

To get the on-line help about the details of BIOS Setup program operation, please apply to the screen tips and the integrated help system.

## 6 Thermal and Power Issues

### 6.1 Temperature Control

Intensive operation of Intel Core 2 Duo processor in harsh environment requires a special technology to keep the processor's die temperature within allowed limits. The following sections provide system integrators with the information, which will help to meet thermal requirements when developing systems based on CPC504.

#### 6.1.1 Passive Regulation

The thermal management concept of CPC504 module includes several separate but correlated functions. Their main purpose is to protect the processor from overheating and reduce its power consumption. Dedicated thermal control subsystem allows the processor to operate within safe temperature range without the need for special software or interrupt handling.

1. **Catastrophic Shutdown Detector** technology allows to automatically switch the processor off when the processor die temperature reaches approximately 125°C due to, for example, the cooling system failure. The catastrophic shutdown detector is based on an internal thermal diode used to detect internal core processor temperature. This function is always active to protect the processor in any case. Processor execution is halted until the next reset cycle. Once this function is activated, the system does not return to the normal operation mode automatically, it is necessary to reset the BIOS settings and to cold restart the system.
2. The Intel® Core 2 Duo processor supports the **Enhanced Intel SpeedStep®** technology. It allows to dynamically switch the processor core voltage and frequency without resetting the system, when the processor core temperature reaches 100°C. For example, the Core 2 Duo L7500 processor operating at 1.6 GHz and 1.2 V can be switched down to 800 MHz and 0.95 V, thus reducing the processor power dissipation.
4. **External thermal monitor** (LM87) gathers information about the processor and board surface temperatures from two sensors. One additional thermal monitor is used to watch the memory modules temperature. This information may then be requested by a program to undertake the appropriate actions.

#### Recommendations

Generally, there is no need to enable the Thermal Management functions if the module is operated in a optimally designed environment with sufficient air flow. However, to guarantee a stable system in unsteady industrial environment, both the internal and the external thermal monitors should be enabled. These two monitors protect the processor and the whole system against overheating.



#### Note:

Thermal Management functions should be disabled when performing Benchmarks and performance tests, otherwise the results will be incorrect due to the power reduction processes influence.

## 6.1.2 Active Regulation

To provide controlled active heat dissipation CPC504 is equipped with a specially designed heatsinks. Together with a system chassis with adjustable forced air flow capability this provides a basis for reliable and steady operation. Forced air flow of sufficient volume is vital for high performance processors operating in high temperature environments.

When developing applications using the CPC504, the system integrator must take into account the overall system thermal requirements. System chassis must satisfy these requirements. When performing thermal calculations for certain application, the developer must consider the contribution of peripherals to be used with the CPC504 to the total heat emission. These devices must also be capable to operate at the temperatures within the system operating range, especially those, which are attached directly to the CPC504 processor module.



### Warning!!!

Since Fastwel does not assume responsibility for any damage to the CPC504 module or other system parts resulting from overheating of the central processor, it is important to ensure that the CPC504 operational environment parameters conform to the thermal requirements described in this Manual.

## 6.2 System Power

The Intel Core 2 Duo processor family require special characteristics of the power supply unit and the backplane.

The CPC504 module itself has been designed to provide best possible power supply for each system unit. However, in order to guarantee reliable and faultless operation the following requirements must be taken into account. Absolute maximum input voltages presented in the table below must not be exceeded to guarantee that the CPC504 is not damaged. The ranges for the different input power voltages, within which the module is functional, are also presented.

**Table 6-1: DC Input Voltage Ranges and Limits**

Power Voltage, V	Maximum Permitted Value, V	Recommended Range, V
+3.3	+3.6	3.135 to 3,465
+5	+5.5	4.75 to 5.25

Power supplies to be used with the CPC504 should comply with these requirements.

Only backplanes which have two power layers for each of the +3.3V and the +5V supply voltage are recommended for CPC504. Input power connections to the backplane itself should provide minimum power loss. Avoid using long input lines, low carrying capacity cables, high resistance connections.

To select the appropriate system power supply, it is necessary to consider the CPC504 own power consumption (about 35 watts), the consumption of the remaining system components, possible variations of power consumption during operation (e.g. due to temperature changes) and some reserve. Taking all this into account, it is recommended to use a 150 watt power supply. If possible, power supplies with voltage sensing should be used. This may require an appropriate backplane.

Consumption currents for CPC504 are: +3.3 V – 2 A, +5 V – 6 A.

## 7 MIC584 Mezzanine Expansion Module

### 7.1 Introduction

MIC584 mezzanine expansion module is designed for installation on Fastwel's CPC504 CompactPCI 3U processor module. This mezzanine I/O module expands functionality and I/O capability of the CPC504. MIC584 module is installed on the top side of the CPC504 processor module and connected via the J2 connector.

#### 7.1.1 MIC584 Versions

At the present time the module is supplied in two versions: MIC584-01-I and MIC584-01-C. They have the same functionality, and differ in the operating temperature range, as shown in the table below:

**Table 7-1: MIC584 Versions Differences**

Version (Order Code)	Operating Temperature Range, °C
MIC58401-I	-40 to +85
MIC58401-C	0 to +70

Protective coating can be applied as an option (\COATED).

#### 7.1.2 MIC584 Delivery Checklist

The MIC584 supplied set includes:

1. MIC584 mezzanine module
2. PS/2 Y-cable
3. Two SATA data cables
4. SATA power cable
5. Two jumpers for XP3, XP4
6. MIC584 and HD mounting kit
7. Antistatic bag for MIC584
8. Consumer package



**Note:**

Keep all the original packaging material (antistatic bag and consumer package) for future storage or warranty shipments.

## 7.2 MIC584 Appearance and Layout

The figures in this section are supposed to help you to locate and identify the module's components and connectors. Our constant efforts in improving our products may result in minor differences between the real module and its depictions.

### 7.2.1 MIC584 Appearance

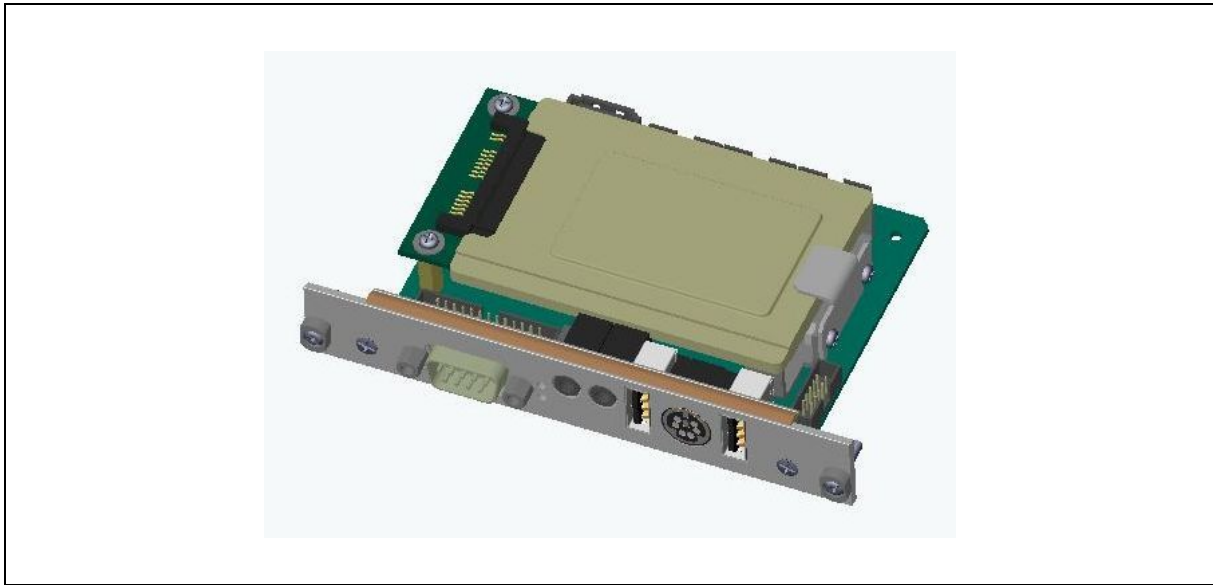
Figure 7-1: MIC584 Appearance



*The appearance of your product may slightly differ from the shown above.*



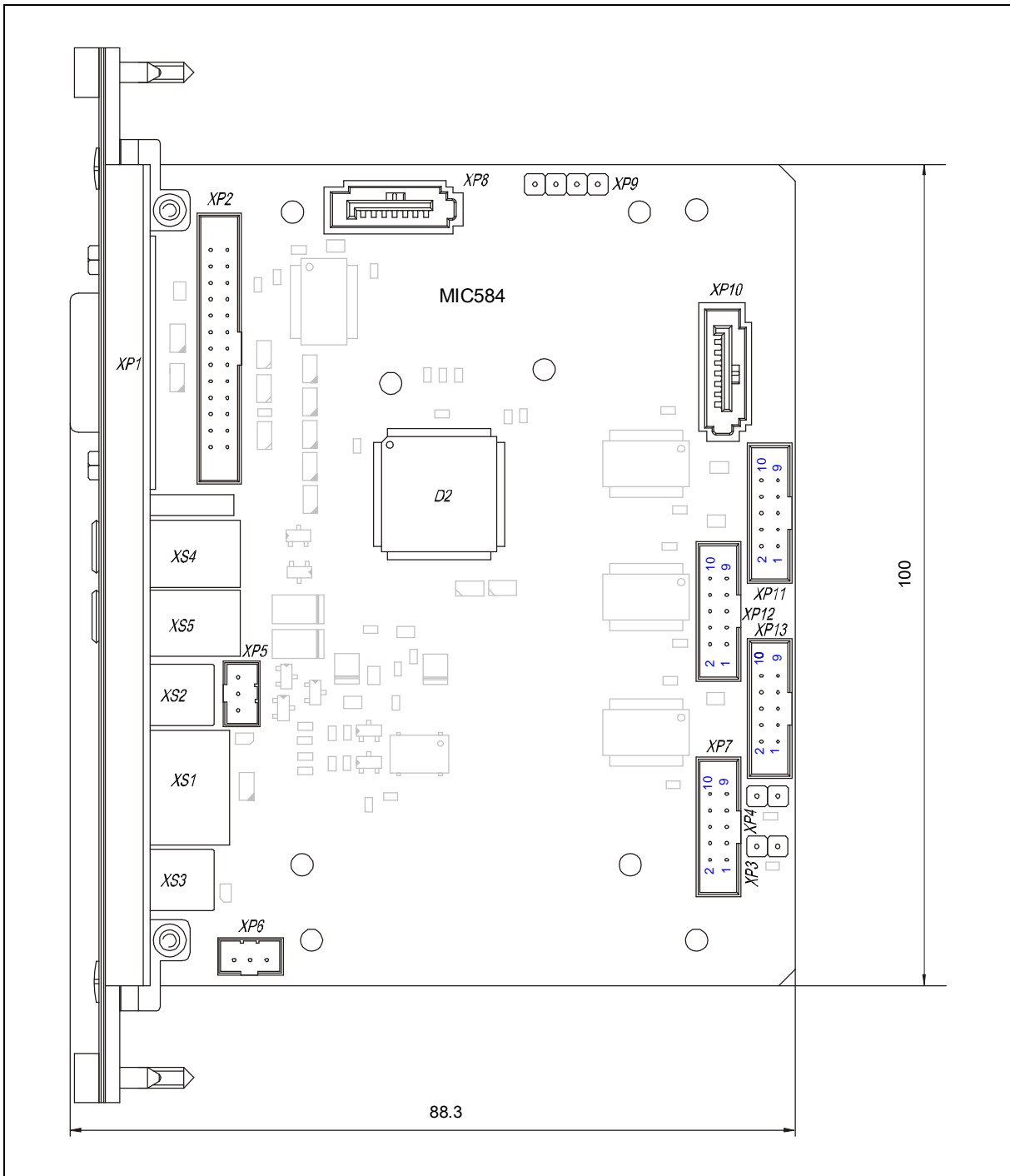
Figure 7-2: MIC584 Appearance with SATA SSD Installed



*Draft. The appearance of your product may slightly differ from the shown above.*

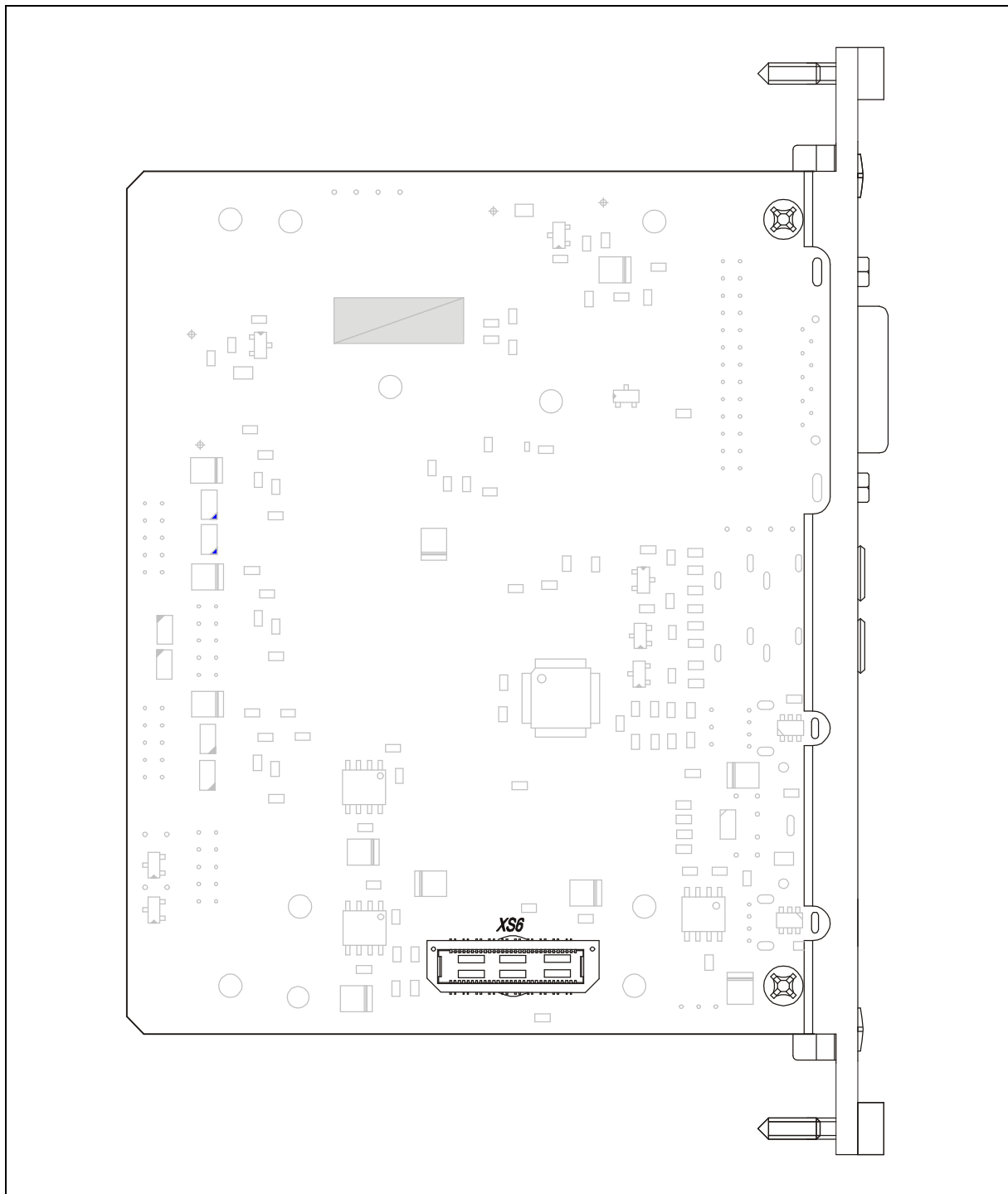
### 7.2.2 MIC584 Components Layout

Figure 7-3: MIC584 Components Layout and Dimensions (Top)



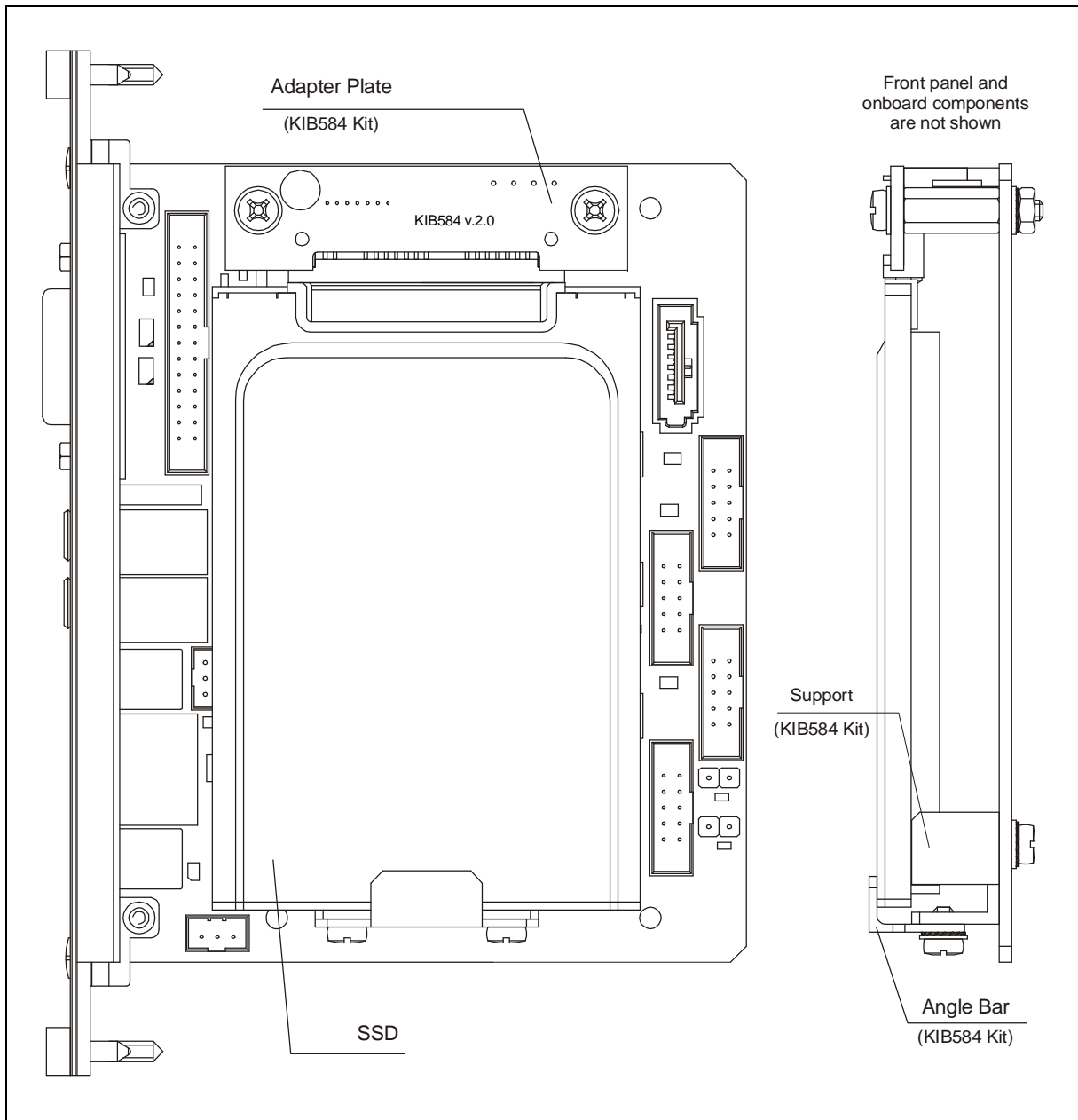
*The module's components layout may slightly differ for various versions of the module.*

Figure 7-4: MIC584 Components Layout (Bottom)



*The module's components layout may slightly differ for various versions of the module.*

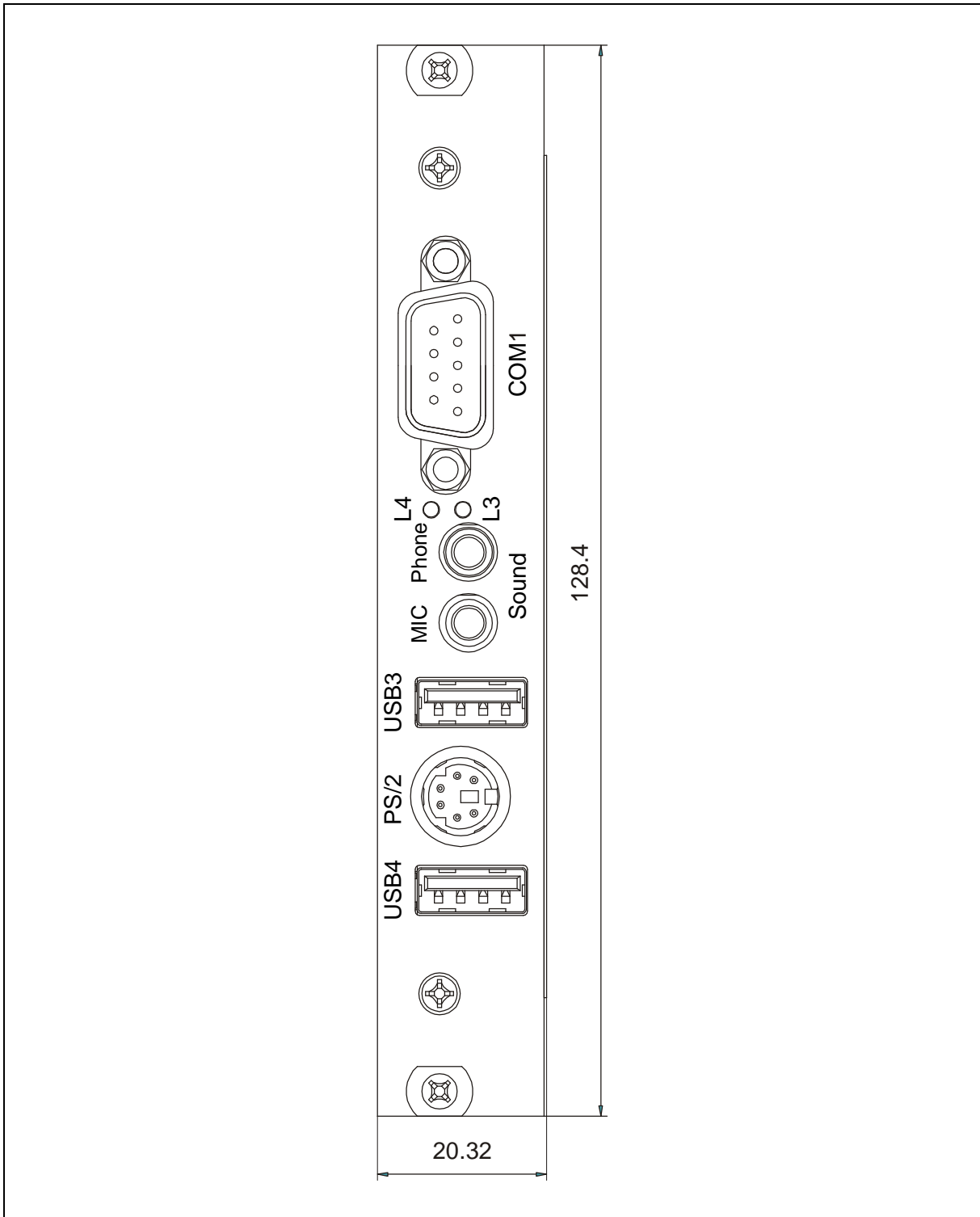
Figure 7-5: MIC584 with 160 GB SSD Installed



*The module's components layout may slightly differ for various versions of the module.*

SSD is not included in the MIC584 supplied set, it is ordered separately. The capacity of the SSD can be 160 GB or 80 GB.

Figure 7-6: MIC584 Front Panel



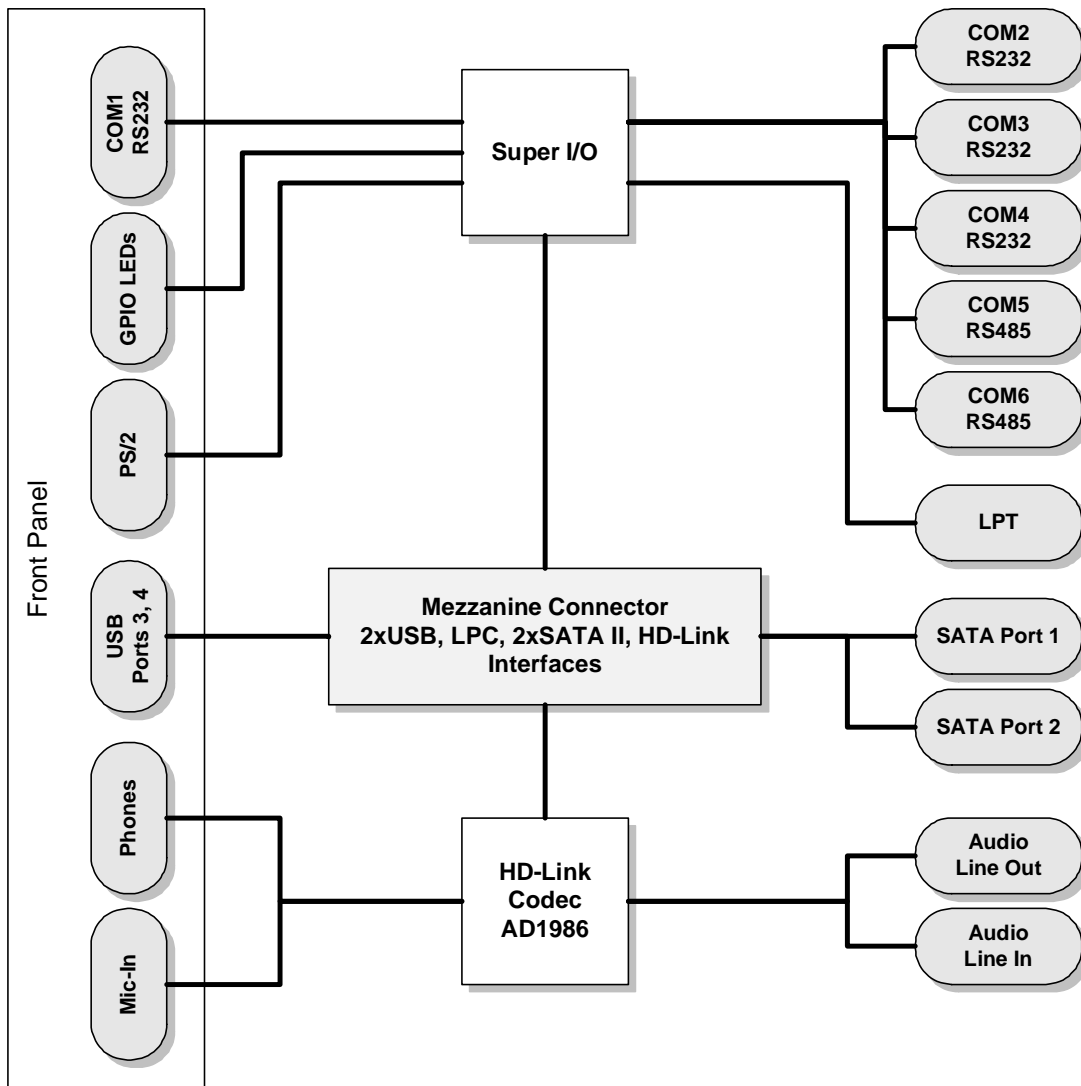
*The module's components layout may slightly differ for various versions of the module.*

## 7.3 Specifications

- **Audio controller: High Definition Audio compatible codec**
  - Line input:  $U_{IN}=1$  V (RMS); XP5 3-pin onboard connector;
  - Line output: output resistance  $Z=10$  K; XP6 3-pin onboard connector;
  - Microphone input:  $U_{IN}=1$  V (RMS) at 0 db amplification;  $U_{IN}=0.1$  V (RMS) at 20 db amplification; front panel connector
  - Headphones output: output resistance  $Z=65$  ohm; front panel connector
- **Two USB ports:**
  - Conform to USB 2.0 specification;
  - Front panel connectors;
  - Routed from CPC504 via XS6 connector.
- **Parallel port (IEEE 1284) (SMSC SCH3116 Super I/O):**
  - Standard mode: Bi-directional SPP;
  - Enhanced mode: EPP v.1.7 and v.1.9;
  - High-speed mode: ECP, IEEE 1284;
  - Onboard connector (IDC2-26).
- **PS/2 interface (SMSC SCH3116 Super I/O):**
  - Standard 6-contact Mini-DIN front panel connector;
  - Y-cable included in supplied set for connection of PS/2 keyboard and mouse.
- **Six serial ports (6x16C550 UART) (SMSC SCH3116 Super I/O):**
  - COM1 – non-isolated RS-232 port, D-Sub9M front panel connector;
  - COM2, COM3, COM4 – non-isolated RS-232 ports; IDC2-10 onboard connectors;
  - COM5, COM6 – non-isolated RS-485 ports; IDC2-10 onboard connector;
- **Serial ATA interface (2 channels):**
  - Connection of up to two external SATA devices using standard cables included in supplied set;
  - One channel can be used for connection of 1.8" SATA HDD or SSD mounted onboard using KIB584 adapter plate;
  - Two onboard connectors.
- **Additional features:**
  - The PCB is reduced to provide better cooling of CPC504 module
- **Does not require forced air cooling**
- **MTBF:** not less than 700000 hours
- **Dimensions:**
  - Reduced 3U cPCI: 88.3 mm × 100 mm (without front panel), 4HP.
- **Power:**
  - +3.3 V  $\pm 5\%$ , 1 A
  - +5 V  $\pm 5\%$ , 2 A
  - Powered from CPC504

## 7.4 MIC584 Block Diagram

Figure 7-7: CPC504 Block Diagram



## 7.5 MIC584 Interfaces

### 7.5.1 MIC584 Interfaces List

#### 7.5.1.1 Front Panel (4HP) Interfaces

The following interfaces are available at the MIC584 front panel:

- COM1 (RS232) interface, 9-pin D-Sub connector
- Two USB 2.0 4-contact sockets (USB3 and USB4), type A
- Two user programmable LEDs: L3 and L4
- PS/2 interface, 6-contact MiniDIN connector for mouse and/or keyboard
- Audio Interface: Phone – output to headphones; Mic – input from microphone

#### 7.5.1.2 Internal Interfaces

The following interfaces are available via the on-board connectors:

- Parallel interface (LPT) connector (26-pin, 2-row, 2.54 mm pitch)
- COM2-COM4 (RS232) interfaces: IDC connectors (10-pin, 2-row, 2.54 mm, XP11-XP13)
- COM5-COM6 (RS485) interfaces: IDC connector (10-pin, 2-row, 2.54 mm, XP7)
- Serial ATA interface: two 7-contact standard connectors
- Audio interface: Line In (3-pin XP5) and Line Out (3-pin XP6)

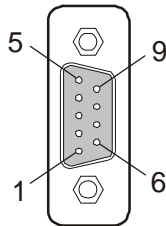


## 7.5.2 MIC584 Interfaces Detailed Description

### 7.5.2.1 Serial Interfaces

Serial ports are realized in SMSC SCH3116 Super I/O chip.

Figure 7-8: COM1 Front Panel Connector

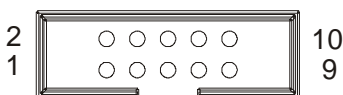


COM1 is a non-isolated RS-232 serial port. It is routed to 9-pin D-Sub connector at MIC584 front panel. Its pinout is presented in the table below.

Table 7-2: COM1 Serial Port Pinout

Pin #	Signal	Pin #	Signal
1	DCD	6	DSR
2	RXD	7	RTS
3	TXD	8	CTS
4	DTR	9	RIN
5	GND		

Figure 7-9: COM2-COM6 Serial Ports IDC2-10 Connector



COM2-COM6 non-isolated serial ports are routed to 2-row 10-pin (IDC2-10) onboard connectors XP11-XP13. Their pinout is presented in the table below.

Table 7-3: RS-232 COM2-COM4 (XP11-XP13) Pinout

Pin #	Signal	Pin #	Signal
1	DCD	6	CTS
2	DSR	7	DTR
3	RXD	8	RIN
4	RTS	9	GND
5	TXD	10	NC

COM5 and COM6 non-isolated RS-485 serial ports are routed to XP7 IDC2-10 onboard connector; its pinout is presented in the table below.

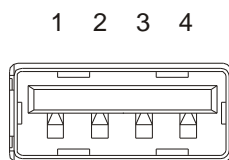
Table 7-4: RS-485 COM5 and COM6 (XP7) Pinout

Pin #	Signal	
1	P1_DATA	COM5
2	P1_DATA#	
3	GND	
4	GND	
5	P2_DATA	COM6
6	P2_DATA#	
7-10	Not used	

If the port is at the end of the line, connection of 120 ohm terminating resistor is required. It is done by closing pins of XP3 (COM5) and XP4 (COM6) 2-pin contacts.

### 7.5.2.2 USB Interfaces

Figure 7-10: USB3 and USB4 Connectors



MIC584 has two USB Type A front panel connectors for connection of USB 2.0 devices. USB interfaces provide 480 Kb/s transfer rate. One device can be connected to each port. For connection of more than two devices to MIC584 module use external USB hub.

Table 7-5: USB3 and USB4 Connectors Pinout

Pin #	Signal	Function	In/Out
1	VCC	VCC signal	–
2	UV0-	Differential USB-	In/Out
3	UV0+	Differential USB+	In/Out
4	GND	GND signal	–

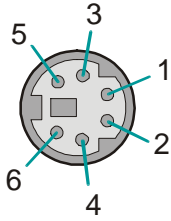


**Note:**

For each USB port maximum current is 0.5 A. All signal lines are EMI filtered.

### 7.5.2.3 PS/2 Keyboard/Mouse Interface

Figure 7-11: PS/2 Connector



PS/2 interface is realized in SMSC SCH3116 Super I/O chip.

Standard 6-pin PS/2 MiniDIN connector is located on the front panel of MIC584. PS/2 keyboard and mouse can be connected simultaneously using Y-cable supplied with MIC584 module.

Table 7-6: PS/2 Connector Pinout

Pin #	Signal	Function	In/Out
1	KDATA	Keyboard data	In/Out
2	MDATA	Mouse data	In/Out
3	GND	GND signal	–
4	VCC	VCC signal	–
5	KCLK	Keyboard clock	Out
6	MCLK	Mouse clock	Out



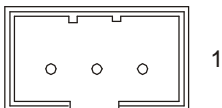
**Note:**

Keyboard/mouse power supply unit is protected by a 500 mA fuse. All signal lines are EMI filtered.

### 7.5.2.4 Audio Interface

Two standard audio connectors are located on MIC584 front panel; they are used for connection of headphones (Phone) and a microphone (Mic).

Figure 7-12: LINE\_IN (XP5) and LINE\_OUT (XP6) Connectors



MIC584 also has two 3-pin onboard connectors: LINE\_IN (XP5) and LINE\_OUT (XP6). Their pinouts are presented in the tables below.

Table 7-7: "LINE\_IN" (XP5) Connector Pinout

Pin #	Signal	Function	In/Out
1	LEFT	Left channel Input	In
2	GND	Ground	–
3	RIGHT	Right channel Input	In

Table 7-8: "LINE\_OUT" (XP6) Connector Pinout

Pin #	Signal	Function	In/Out
1	LEFT	Left channel output	Out
2	GND	Ground	–
3	RIGHT	Right channel output	Out

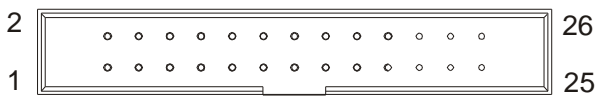
### 7.5.2.5 L3 and L4 LEDs

There are two programmable LED indicators (L3 and L4) on the front panel of MIC584.

### 7.5.2.6 LPT Interface

Parallel port interface of MIC584 is realized in SMSC SCH3116 Super I/O chip and is routed to 2-row 26-pin onboard LPT connector (XP2). For connection of a standard parallel cable an adaptor is needed.

Figure 7-13: LPT Connector (XP2)



LPT contacts numbering;  
the pinout is in the table below.

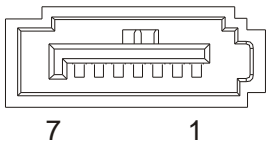
Table 7-9: LPT Connector Pinout

Pin #	Signal	In/Out	Pin #	Signal	In/Out
1	STROBE	Out	14	GND	–
2	AUTOFD	Out	15	PD6	In/Out
3	PD0	In/Out	16	GND	–
4	ERROR	In	17	PD7	In/Out
5	PD1	In/Out	18	GND	–
6	INIT	Out	19	ACK	In
7	PD2	In/Out	20	GND	–
8	SLCTIN	Out	21	BUSY	In
9	PD3	In/Out	22	GND	–
10	GND	–	23	PE	In
11	PD4	In/Out	24	GND	–
12	GND	–	25	SLCT	In
13	PD5	In/Out	26	GND	–

### 7.5.2.7 SerialATA Interface

External SATA drives can be connected to MIC584 via two standard onboard SerialATA connectors – XP8 and XP10. For installation of a 1.8” disk drive on MIC584 the KIB584 adaptor is used; power to the drive is supplied via XP9 connector. KIB584 adaptor is a part of ACS20044 set which is not supplied with MIC584 and can be ordered separately.

**Figure 7-14: SerialATA Connector**



Recommended SATA cable length – 45 cm.  
The pinout is in the table below.

**Table 7-10: SerialATA Connector Pinout**

Pin #	Signal	Pin #	Signal
1	GND	5	RXN
2	TXP	6	RXP
3	TXN	7	GND
4	GND		

## 8 MIC588 2xDVI Module

### 8.1 Introduction

MIC588 is a mezzanine 3U cPCI interface expansion module equipped with two DVI-D connectors. It is designed to be installed on the bottom side of Fastwel's CPC504 CompactPCI 3U processor module (versions CPC504-03 and -04 only) and connected via the J1 connector. Video output can be directed either to the MIC588 front panel or to CompactPCI connectors to be available via RIO588 rear I/O module. The output is switched with the help of BIOS Setup utility on CPC504. Front panel output is indicated by the ACT LED.

MIC588 is powered via CompactPCI backplane.

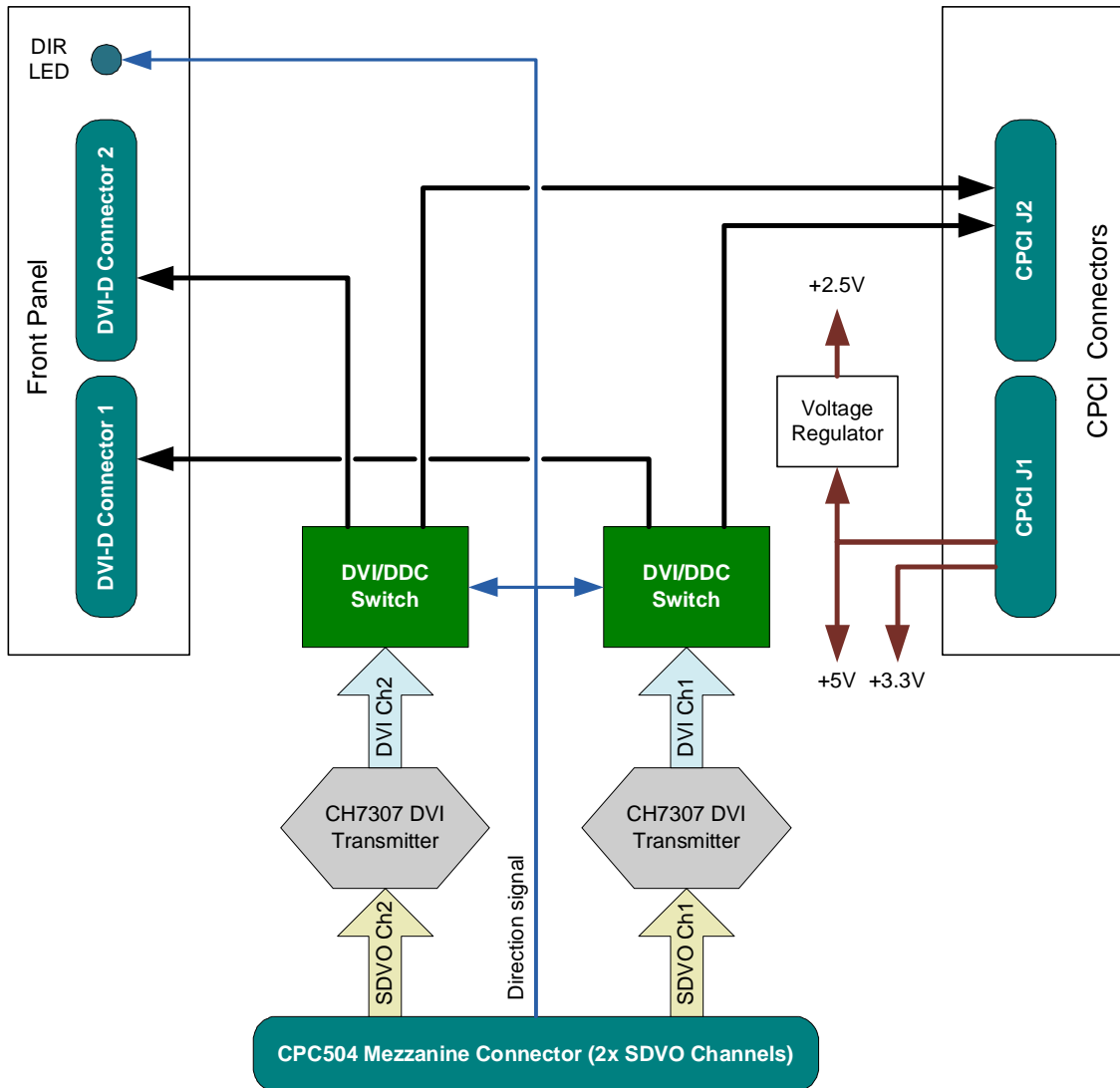
MIC588 is included in the supplied set of versions -03 and -04 of the CPC504 processor module and normally is not supplied separately.

### 8.2 Specifications

- **SDVO-DVI transmitters:**
  - MIC588 includes two SDVO-DVI transmitters;
  - Transmission rate: 165 megapixels/s;
  - Resolution: up to UXGA (1600×1200) (single-channel DVI-D).
- **Two DVI-D ports:**
  - Front panel connectors;
  - Software switchable output to front panel or rear I/O.
- **Other:**
  - The module is connected to CPC504 processor module via Samtec high-speed differential connector;
  - Front panel output mode indicator.
- **Does not require forced air cooling**
- **Dimensions:**
  - 3U cPCI: 181.3 mm x 100 mm, 4HP.
- **Power:**
  - +3.3 V ±5%, 200 mA
  - +5 V ±5%, 380 mA
- **Shock/Vibration stability:**
  - Vibration: 5g
  - Single shock: 100g
  - Multiple shock: 50g

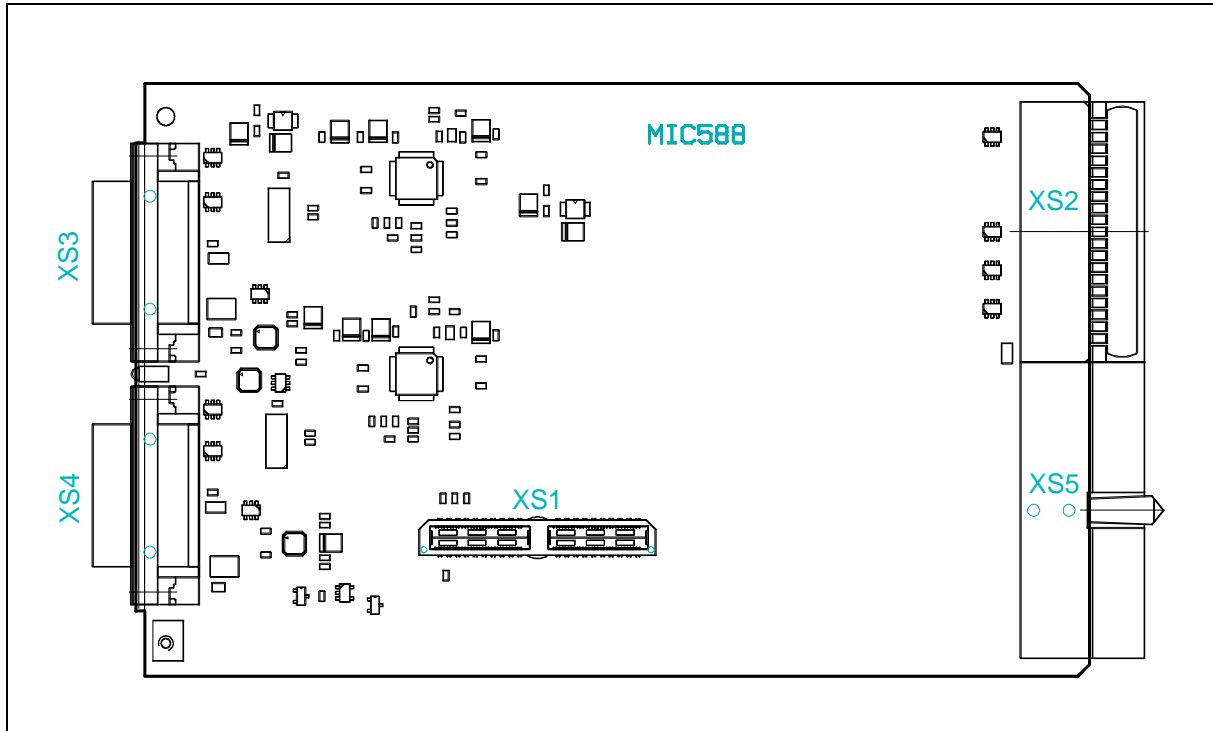
### 8.3 MIC588 Block Diagram

Figure 8-1: MIC588 Block Diagram



## 8.4 MIC588 Layout

Figure 8-2: MIC588 Layout (Side Facing CPC504)



*The layout of your product may slightly differ from the shown above.*



## 8.5 DVI-D Connectors

Two digital monitors can be connected to MIC588 front panel connectors; the pinout is shown below.

**Table 8-1: DVI-D Connector Pinout**

Pin #	Signal	Pin #	Signal
1	DATA2-	16	HP_DETECT
2	DATA2+	17	DATA0 -
3	DTA2/ SHIELD	18	DATA0+
4	NC	19	DTA0_SHIELD
5	NC	20	NC
6	DDC_CLK	21	NC
7	DDC_DAT	22	CLK_SHIELD
8	NC	23	CLOCK+
9	DATA1 -	24	CLOCK -
10	DATA1+	25	NC
11	DTA1_SHIELD	26	NC
12	NC	27	NC
13	NC	28	NC
14	+5V_PWR	29	AGND
15	GND		



## 9 Supplementary Information

### 9.1 Related Standards and Specifications

The Fastwel's CompactPCI modules comply with the requirements of the following standards:

**Table 9-1: Related Standards**

Type	Standard	Test Parameters
CE: Emission	EN50081-1	–
CE: Immission	EN61000-6-2	–
CE: Electrical safety	EN60950-2002	–
Mechanical dimensions	IEEE 1101.10	–
Vibration (sinusoidal)	IEC60068-2-6-82; Fc	5 g / 10-500 Hz / 10 (acceleration / frequency range / test cycles per axis)
Permanent shock	IEC60068-2-29-87; Eb	50 g / 11 ms / 1000±10 / 1 s (peak acceleration / shock duration half sine / number of shocks / recovery time)
Single shock	IEC60068-2-27-87; Ea	100 g / 9 ms / 18 / 3 s (peak acceleration / shock duration / number of shocks / recovery time in seconds)



#### Important...

Some versions of the module may have the test results differing from the ones presented in the above table. For more information please contact Fastwel's official representatives.

Information related to this product and its components can be found in the following specifications:

**Table 9-2: Related Specifications**

Product	Specification
CompactPCI Systems and Boards	CompactPCI Specification 2.0, Rev. 3.0

## 10 Useful Abbreviations, Acronyms and Short-cuts

Abbreviation	Meaning
BMC	Baseboard Management Controller
PM	Peripheral Management Controller
IPMI	Intelligent Platform Management Interface
IPMB	Intelligent Platform Management Bus
I <sup>2</sup> C™	Inter Integrated Circuit Two-thread serial protocol, used in SMB and IPMI
KCS interface	Keyboard Controller Style interface Interface for communication between control software and BMC, similar to a keyboard controller interface
BT interface	Block Transfer interface Block transfer interface for communication between control software and BMC
DDR SDRAM	Double Data Rate Synchronous Dynamic Random Access Memory
SODIMM	Small Outline Dual In-Line Memory Module
ECC	Error Correction Code Data error correction technology used in memory modules
FWH	Firmware Hub Nonvolatile memory chip, part of Intel chipset, used for main and reserve BIOS copies in CPC504
GMCH	Graphics and Memory Controller Hub
DAC	Digital-Analog Converter
USB	Universal Serial Bus
LPC	Low Pin Count External devices communication interface
SMB	System Management Bus
UART	Universal Asynchronous Receiver-Transmitter
UHCI	Universal Host Controller Interface USB Host Controller Interface
EHCI	Enhanced Host Controller Interface (Universal Serial Bus specification)
UTP	Unshielded Twisted Pair
CRT-display	Cathode Ray Tube Display
PMC	PCI (Peripheral Component Interconnect) Mezzanine Card
CMC	Common Mezzanine Card
LVDS	Low Voltage Differential Signal Digital monitors communication specification
RTC	Real Time Clock
BIOS	Basic Input-Output System
PC	Personal Computer
PICMG	PCI Industrial Computer Manufacturers Group
AHA	Accelerated Hub Architecture GMCH and ICH communication bus specification

Abbreviation	Meaning
AGP	Accelerated Graphics Port
AGTL	Advanced Gunning Transceiver Logic PSB (Processor Side Bus) signal exchange specification
SMBus	System Management Bus
EEPROM	Electrically Erasable Programmable Read-Only Memory
NAND Flash	Not And (electronic logic gate) Flash memory specification
SSD	Solid State Disk
PLCC	Plastic Leaded Chip Carrier
RAMDAC	Random Access Memory Digital-to-Analog Converter
DAC	Digital-to-Analog Converter
DVMT	Dynamic Video Memory Technology
TTL	Transistor-Transistor Logic
ECP/EPP	Extended Capabilities Port / Enhanced Parallel Port Parallel port specifications
FDD	Floppy Disk Drive
EIDE	Enhanced Integrated Drive Electronics Mass storage devices interface
DMA	Direct Memory Access
PIO	Programmed Input/Output EIDE: Directly processor controlled data exchange
Rear I/O Board	Rear Input-Output Board Auxiliary interface board, which is connected to the cPCI backplane rear connectors
PWM output	Pulse-Width Modulation Cooling fan control technique
ESD	Electrostatically Sensitive Device Electrostatic Discharge
ACPI	Advanced Configuration and Power Interface
POST	Power On Self Test
cPCI	CompactPCI Industrial automation systems standard
EOS	Electrical Overstress
MDI	Media Dependent Interface Interface with connection type automatic detection