

CPC1302

Mezzanine COM Express Basic CPU Module

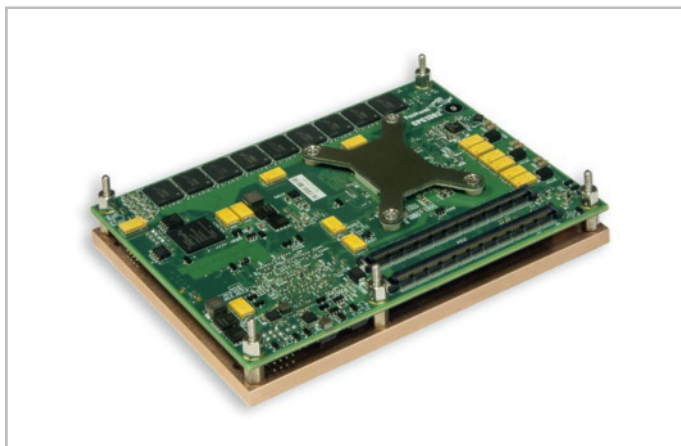

Overview

CPC 1302 Mezzanine COM Express Basic CPU Module is implemented in the standard COM Express Basic format, provides developers of embedded systems with such capabilities as: compatibility with x86, the most up-to-date set of functional capabilities based on PCI Express 3.0, SATA 3.0, USB 3.0, DisplayPort 1.2 interfaces, high performance of Core I7 CPUs of the latest generation.

Features

- Intel Core i7-5850EQ CPU 2.7Ghz 5th Gen. 37W / Intel Core i5-4422E CPU 1.8Ghz 4th Gen. 25W
- RAM: DDR3L-1600 SDRAM up to 8 GB with ECC support
- Real-Time Clock (power supply from the port "RTC battery")
- Watchdog timer
- Power supply: +8 V...14 V from COM-Express connector
- Operating temperature: 0°C to +70°C / -40°C to +85°C
- Weight: no more than 0.8 kg
- Software compatibility: Linux 3.8.x, QNX 6.x, Microsoft Windows Embedded Standard 7 / 8

Technical Specifications

Intel Core i7-5850EQ CPU 2.7 Ghz 5th Gen. 37W

- 4x cores Intel x64
- 3x graphics kernels
- 6 MB cache

Intel Core i5-4422E CPU 1.8 Ghz 4th Gen. 25W

- 2x cores Intel x64
- 2x graphics kernels
- 3 MB cache

RAM

- DDR3L-1600 SDRAM up to 8 GB with ECC support
- 64-bit data bus

FLASH BIOS

- 128 Mb SPI-Flash
- Modifiable within the system

FRAM 32 KB (SPI port) for storing user data

COM-Express Type 6 connector

- 1x port PCIe x16 GEN3, 8 GT/s
- 7x ports PCIe x1 GEN2, 5 GT/s
- 8x ports USB 2.0
- 4x ports USB 3.0
- 4x ports SATA III 6Gbps
- Port "LAN 0": Gbit Ethernet Intel 210
- Port SPI (External Boot)
- Port "LVDS Channel": LVDS Dual Channel 24 bit 1920x1200@60Hz
- 3x ports DDI 4096x2304@60Hz
- 1x port VGA CRT 1920x2000@60Hz
- Port LPC (Specification Rev. 1.1)
- Port SMBus
- Port I²C
- Port HD Audio
- Speaker Out
- 4x ports GPIO
- 2x ports RS-232 (TTL, 128-byte FIFO, up to 3 Mbps)

Real-Time Clock (power supply from the port "RTC battery")

SSD 16 GB drive in SATA interface

Watchdog timer

Monitor of 7 power supply voltages, monitor of PCB temperature

Console I/O via serial ports (COM1 / COM2)

Software compatibility

- Linux 3.8.x
- QNX 6.x
- Microsoft Windows Embedded Standard 8
- Microsoft Windows Embedded Standard 7

Power supply

- +8 V...14 V from COM-Express connector
- +5 V STBY from COM-Express connector (as an option)

Power consumption

- 51W for CPC1302-01-(-02)
- 38W for CPC1302-03-(-04)

Operating temperature

- From 0° C to +70° C for CPC1302-01 (-02)
- From -40° C to +85° C for CPC1302-03 (-04)

Module weight with heat-spreader

- No more than 0,8 kg

MTBF

- No less than 100 000 hours



CPC1302

Mezzanine COM Express Basic CPU Module

Board Layout

CPC1302 diagram v.04

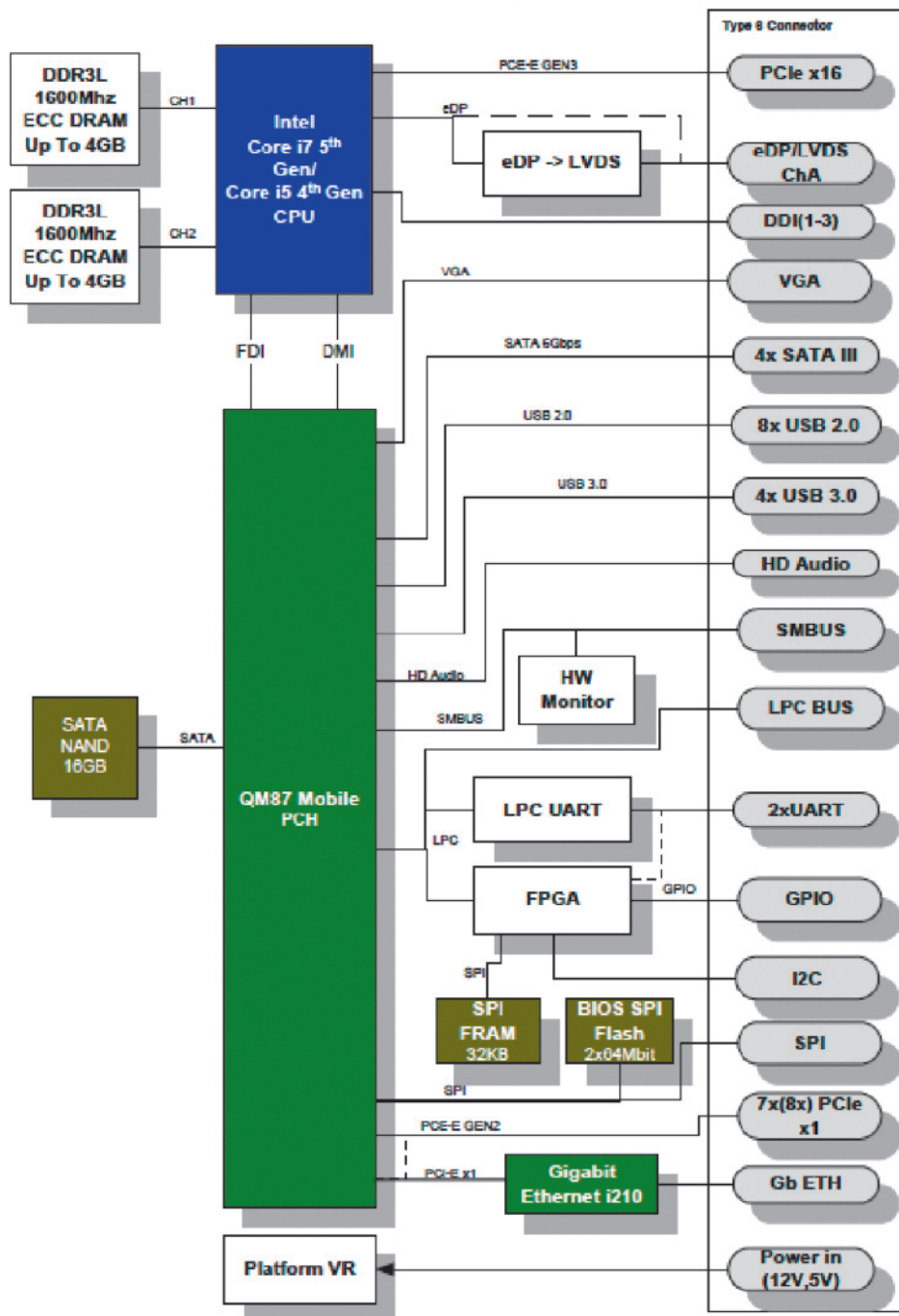

Fastwel



Fastwel



Fastwel

CPC1302

Mezzanine COM Express Basic CPU Module

Ordering Information

CPC1302 Configuration

CPC1302 - 01 \ Options

Configurations

CPC1302-01	Intel Core i7-5850EQ 2.7 GHz 4C 37W, RAM 8 GB 1600 DDR3L, SSD 16 GB, temperature: 0...+70°C
CPC1302-02	Intel Core i7-5850EQ 2.7 GHz 4C 37W, RAM 8 GB 1600 DDR3L, temperature: 0...+70°C
CPC1302-03	Intel Core i5-4422E 1.8 GHz 2C 25W, RAM 4 GB 1600 DDR3L, SSD 16 GB, temperature: -40...+85°C
CPC1302-04	Intel Core i5-4422E 1.8 GHz 2C 25W, RAM 4 GB 1600 DDR3L, temperature: -40...+85°C

Available options for CPC1302

\LNX*	Linux 3.8.x
\COATED**	Conformal coating

Available accessories

Heat-removal system (***)

ACS30076	Heatsink
ACS30076-01	Heatsink with fan

(*) Pre-installation of OS is possible for versions equipped with SSD.

(**) Coating is available only for industrial versions.

(***) Module is supplied ready-assembled with the heat-spreader.

Delivery checklist

CPC1302 delivery checklist contains

1. CPC1302 CPU Module
2. Package

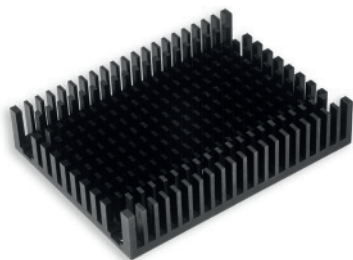

Ver.1.01.2016

Product specifications are subject to change without notice

Corporate Offices

FASTWEL GROUP Co., Ltd

108 Profsoyuznaya str.
Moscow, Russia 117437
Tel: +7 (495) 232-1681
Fax: +7 (495) 232-1654
E-mail: info@fastwel.com
Web: www.fastwel.com

COM 
Express

READY FOR



RoHS



Fastwel



Fastwel



Fastwel