

# CPC108

## MicroPC Processor Module

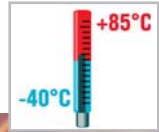

**Best solutions  
to fit your demands!**

- AMD Geode LX800 (500 MHz) processor
- 256 MB DDR SDRAM
- Support for LCD panels (resolution up to 1600×1200) and CRT monitors (resolution up to 1920×1440)
- Flash-disk 64 MB
- FDD/LPT (EPP, ECP) interfaces
- USB 1.1, 2.0 support
- Fast Ethernet port 10/100 Mb/s
- Four COM ports (two isolated)
- Industrial operating temperature range: -40°C to +85°C
- Protective coating (option)



## Features

- AMD Geode LX800 (500 MHz) processor
- 256 MB DDR SDRAM (soldered)
- Support for LCD panels (resolution up to 1600×1200) and CRT monitors (resolution up to 1920×1440)
- Flash disk 64 MB (soldered)
- FDD/LPT (EPP, ECP) interfaces
- USB 1.1, 2.0 support
- Fast Ethernet port 10/100 Mb/s
- Four COM ports (two isolated)
- Industrial operating temperature range: -40°C to +85°C
- Protective coating (option)

## Overview

CPC108 is a compact yet fully x86-compatible SBC in MicroPC format, designed for fanless operation in harsh environments. Key system components, such as processor, 256 MB of system memory, and 64 MB solid-state disk are soldered on board, providing high shock and vibration stability. High system reliability and availability are ensured by two independent watchdog timers, reserved BIOS, and opto-isolated remote reset capability.

CPC108 offers wide choice of standard PC interfaces on-board, such as Fast Ethernet, FDD/LPT port, COM and USB ports, PS/2 mouse and keyboard ports, and audio interface. Video controller sharing up to 60 MB of memory with system supports CRT monitors with resolutions up to 1920×1440, and EL, TFT and DSTN flat panels with resolutions up to 1600×1200. Supported color depth is 18 bit via TFT interface, and 24 bit via LVDS interface.

Moreover, the board has two isolated CAN field bus channels available, allowing to control a real time distributed system. CPC108 can serve either as a master module controlling two CAN network segments, or as a slave device in data acquisition and processing systems operating in industrial temperature range.

Isolated CAN channels, graphics and audio ports, keyboard and mouse ports as well as isolated reset are available through separately mounted interface expansion modules adding flexibility in system design.

CPC108 consumes only 5.5 W, does not require forced cooling. Low heat dissipation allows using CPC108 in closed and hermetically sealed cabinets. It can operate either independently, or together with expansion modules connected via 16-bit ISA bus.

Compatibility with most widespread operating systems, such as Windows XP Embedded, CE, QNX 4.25, 6.3x and Linux makes system development process faster.

## Technical Specifications

### System

- AMD Geode LX800 (500 MHz): 32-bit x86 core; 64-bit coprocessor; 64-bit memory bus; 64 KB L1 cache; 128 KB L2 cache; MMX®, 3DNow!™ support
- 256 MB DDR SDRAM
- Two watchdog timers: one programmable timer and one hardware timer with fixed timeout period
- Real time clock
- MTBF: 180 000 hours

### Flash BIOS

- 2×512 KB reserved BIOS
- In-system modification
- CMOS+SFRAM for configuration parameters saving

### Graphics

- 2D accelerator
- Up to 60 MB display memory (shared with system)
- LCD (TFT or DSTN) panels support, resolution 1024×768 (60 Hz); 18-bit color connected directly via TFT interface; 24-bit via LVDS interface
- CRT monitors support, 1600×1200 (100 Hz), 1920×1440 (85 Hz, 32-bit)

### Storage

- Flash-disk: 64 MB
- EIDE interface: handles up to two devices (Primary channel), UltraDMA/100 support
- CompactFlash Type I/II socket
- ATA 100 interface
- DiskOnChip® socket: SRAM and FRAM (32/28 pins) modules support
- Isolated reset

### Software Support

- Fastwel DOS™ (MS™ DOS compatible)
- QNX® 4.25, 6.3x
- Windows® XPE
- Windows® CE
- Linux®

### Interfaces

- Fast Ethernet port 10/100 Mb/s
- USB 1.1, 2.0 support, up to four devices connection; 3 host ports, 1 host/device
- Serial ports:  
COM1, COM2: RS232, complete, up to 115.2 Kb/s  
COM3, COM4: RS422 / RS485, isolated
- Console operation via COM1 or COM2 serial ports
- Two CAN ports: available via KIB985 module, isolated
- AC'97 compatible audio: stereo Line in/Line out, microphone input
- PS/2 keyboard and mouse port
- FDD / LPT (EPP, ECP) interfaces share one connector

### Mechanical

- Dimensions: 125.0×123.0×23.0 mm (4.92"×4.84"×0.90")
- Weight: 0.100 kg

### Power Supply Options

- 5 V ±5%, 1.3 A

### Environmental conditions

- Operating temperature: -40°C to +85°C
- Storage temperature: -55°C to +90°C

### Warranty

- 3 years for parts and labor

### List of deliverables

- CPC108 processor module
- ACS00023 – cable for connection to COM1, COM2 ports
- ACS00010 – cable for connection of 2.5" HDD
- CDM02 – adapter module for connection of 3.5" HDD and CD-ROM
- KIB981 – interface expansion module for connection of TFT panel or VGA monitor, PS/2 keyboard and mouse, audio devices
- ACS00015 – cable for connection of KIB981 module
- CD-ROM with documentation and service SW

## Board Layout

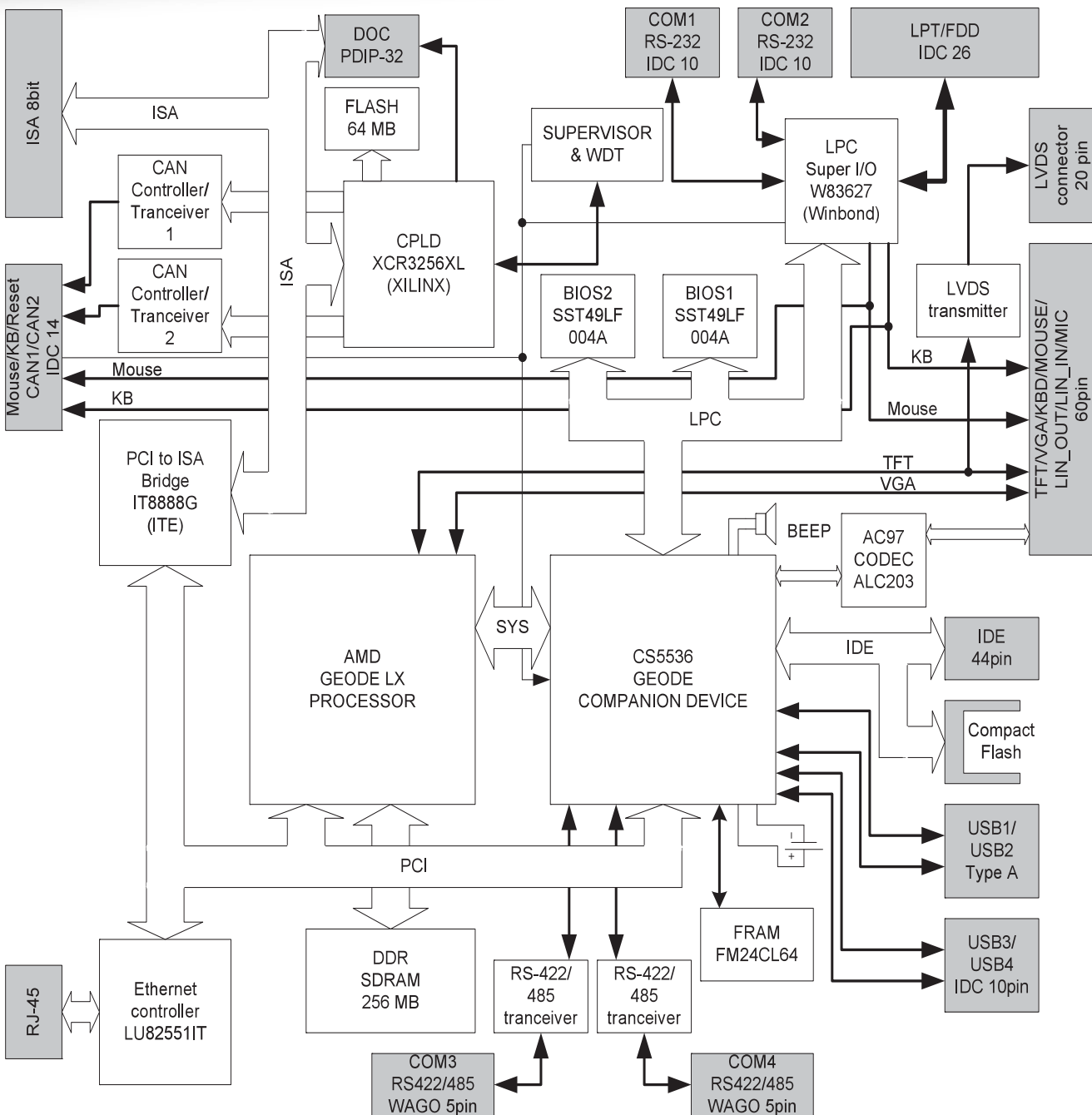

## Expansion Capabilities

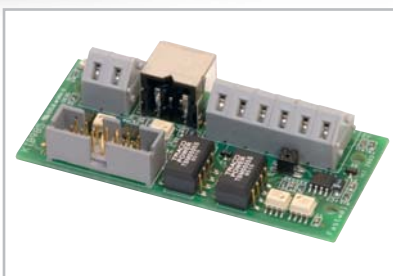

### KIB985 module is designed for connecting following devices to CPC108:

- Keyboard and mouse PS/2 (MiniDIN6 socket, requires Y-cable for simultaneous connection)
- CAN2.0B network (socket for WAGO 236-406 spring clip with opto-isolation up to 1000 V between channels and system, and termination resistor 120 ohm connectivity for CAN1: JP1[1-2]=ON, for CAN2: JP1[3-4]=ON)
- RESET signal with active level from 3.3 V to 12 V (socket for WAGO 236-402 spring clip, isolation up to 1500 V)

The module is equipped with adapters for DIN-rail mounting and holes for crate mounting (F520x (Fastwel) and 520x (Octagon Systems) series crates).

## Ordering Information

### CPC108 Configuration

#### CPC10801 \Options

##### Device Type

CPC10801	Dual CAN, Ethernet 10/100, LVDS
CPC10802	Dual CAN
CPC10803	Ethernet 10/100

### CPC108 Available Options

Compact Flash Module	
\CF1024	1024 MB Compact Flash, industrial
\CF2G	2 GB Compact Flash, industrial
\CF4G	4 GB Compact Flash, industrial
\CF8G	8 GB Compact Flash, industrial
\CF16G	16 GB Compact Flash, industrial
Coating	
\COATED	Protective Coating
Operating System Presetting	
\FDOS	Fastwel DOS
\QNX	QNX 6.3x, 4.25
\WCE	Windows CE
\WXPE	Windows XP Embedded
\LNX	Linux 2.4.20

Other configurations and options are available upon request.

#### Example

##### CPC10801 \COATED

MicroPC, AMD Geode LX800 Module, Dual CAN, Ethernet 10/100, LVDS  
Protective coating

Ver. 1.2 2009

Product specifications are subject to change without notice

## Applications



Embedded



Process Control



Avionics



Transportation

## Corporate Offices

#### FASTWEL GROUP Co. Ltd

108 Profsoyuznaya str.  
Moscow, Russia 117437  
Tel: +7 (495) 232-1681  
Fax: +7 (495) 232-1654  
E-mail: info@fastwel.com  
Web: www.fastwel.com

#### FASTWEL Corporation US

55 Washington street, Suite 310  
Brooklyn, NY 11201  
Tel: 1.718.554.3686  
Fax: 1.718.797.0600  
Toll free: 1.877.787.8443  
(1.877.RURUGGED)  
E-mail: info@fastwel.com

#### FASTWEL Asia

6F., No. 118, Ln.235, Baoqiao  
Rd., Xindian Dist,  
New Taipei City, Taiwan, R.O.C.  
Tel: +886-2-8912 1938  
Fax: +886-2-8912 1939  
E-mail: asia@fastwel.com

READY FOR



RoHS



MICRO



Fastwel



Fastwel



Fastwel