

CPC1301

COM Express Module based on Intel® Core® 2 Duo CPU

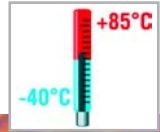

**Best solutions
to fit your demands!**

- Intel® Core® 2 Duo/Core Duo/Celeron CPUs with 533/667 MHz FSB
- COM Express Type II pinout
- Up to 4 GB DDR2 dual channel memory
- CRT and LVDS
- 5 x1 or 1 x4 and 1 x1 PCI-Express
- x16 PCI Express graphics interface
- Gigabit Ethernet port
- I2c bus
- Eight USB 2.0 ports
- Two Serial ATA, one IDE Ultra ATA/100 interface
- Extended temperature range

CPC1301

COM Express module based on Intel® Core® 2 Duo CPU



Features

- Intel® Core® 2 Duo/Core Duo/Celeron CPUs with 533/667 MHz FSB
- COM Express Type II pinout
- Up to 4 GB DDR2 dual channel memory
- CRT and LVDS
- Up to 5 x1 or 1 x4 and 1 x1 PCI-Express
- x16 PCI Express graphics interface
- Gigabit Ethernet port
- I2c bus
- Eight USB 2.0 ports
- Two Serial ATA, one IDE Ultra ATA/100 interface
- Extended temperature range

Overview

CPC1301 is a COM Express Module based on Intel® Core® 2 Duo/Core Duo/Celeron CPUs up to 2.16 GHz with 533/667 MHz front side bus and Intel chipset comprising 945GM GMCH and ICH7M. Memory interface supports dual DDR2 SDRAM through two SODIMM sockets with total capacity of up to 4 GB.

Multimedia functions are supported by interfaces for CRT-monitor, flat panels with dual LVDS interface and AC'97 audio codec. External graphic adapters can be connected through x16 PCI Express interface.

Gigabit Ethernet channel makes this board perfect for developing communication intensive applications.

Peripheral devices can be connected to CPC1301 through PCI Express interfaces, 8 high-speed USB 2.0 ports, LPC, AC'97.

CPC1301 storage subsystem supports two SATA and one IDE Ultra ATA/100 disk drives.

CPC1301 supports Suspend-to-RAM mode.

For performance evaluation and application stack development, Fastwel provides development board — KIB1280, which gives access to all features of CPC1301 and facilitates software and hardware design.

Additional reliability of CPC1301 is provided by hardware monitoring, watchdog timer, reserved CMOS memory and a set of system monitoring features.

CPC1301 operates in industrial (-40°C to +85°C) and commercial (0°C to +70°C) temperature ranges.

Technical Specifications

System

- CPUs:
 - Intel® Core® 2 Duo processor 2.16 GHz, 4 MB cache L2, 667 MHz FSB
 - Intel® Core® 2 Duo processor 1.5 GHz, 4 MB cache L2, 667 MHz FSB
 - Intel® Core® Duo processor 1.66 GHz, 2 MB cache L2, 667 MHz FSB
 - Intel® Celeron® M 423 processor, 1.06 GHz, 2 MB cache L2, 533 MHz FSB
- Chipset: 945GM GMCH & ICH7M
- Up to 4 GB DDR2 SDRAM, two SODIMM sockets
- CPU temperature and voltage control sensors
- Reserved CMOS memory
- MTBF: 140 000 hours

BIOS

- Phoenix® BIOS with
 - LAN Boot
 - USB Boot
 - Multi Boot
 - Quick Boot

Graphics

- Video controller integrated into 945GM
- Video memory up to 64 MB shared with system
- Analog display interface supports resolutions up to 2048x1536 @ 75 Hz
- Dual LVDS
- TV-Out

Storage

- One IDE Ultra ATA/100 interface connector
- Two Serial ATA interfaces

Software support

- Fastwel DOS™ (MS™ DOS compatible)
- Windows XP Embedded
- Linux® 2.6
- QNX 4.2, 6.0

I/O Interfaces & Expansion

- One Gigabit Ethernet port 10/100/1000 Mb/s
- One x16 PCI Express interface

- 5 x1 PCI-Express, also configurable as 1 x1 and 1 x4
- 32-bit PCI interface
- AC'97 interface
- LPC interface
- Express Card interface support
- Eight USB 2.0 ports

Mechanical

- Dimensions: 95x125 mm (3.74"x4.92")
- Weight: 0.15 kg

Power requirements

- +12 V @ 4 A and +5 V @ 1 A

Environmental conditions

- Operating temperature:
 - 40°C to +85°C — industrial
 - 0°C to +70°C — commercial
- Storage temperature: -50°C to +95°C
- Humidity: 95% noncondensing
- Shock/Vibration: 50G/2G
- Cooling system: heat spreader and radiator

Compliance

- PICMG COM.0. COM Express Module Base Specification Rev. 1.0. Pin-out type II

List of Deliverables

- CPC1301 Module
- Screws set
- Cooling system for CPU and GMCH hub
- CD with drivers and documentation

Warranty

- 3 years for parts and labor



CPC1301 with radiator and fan

Board Layout

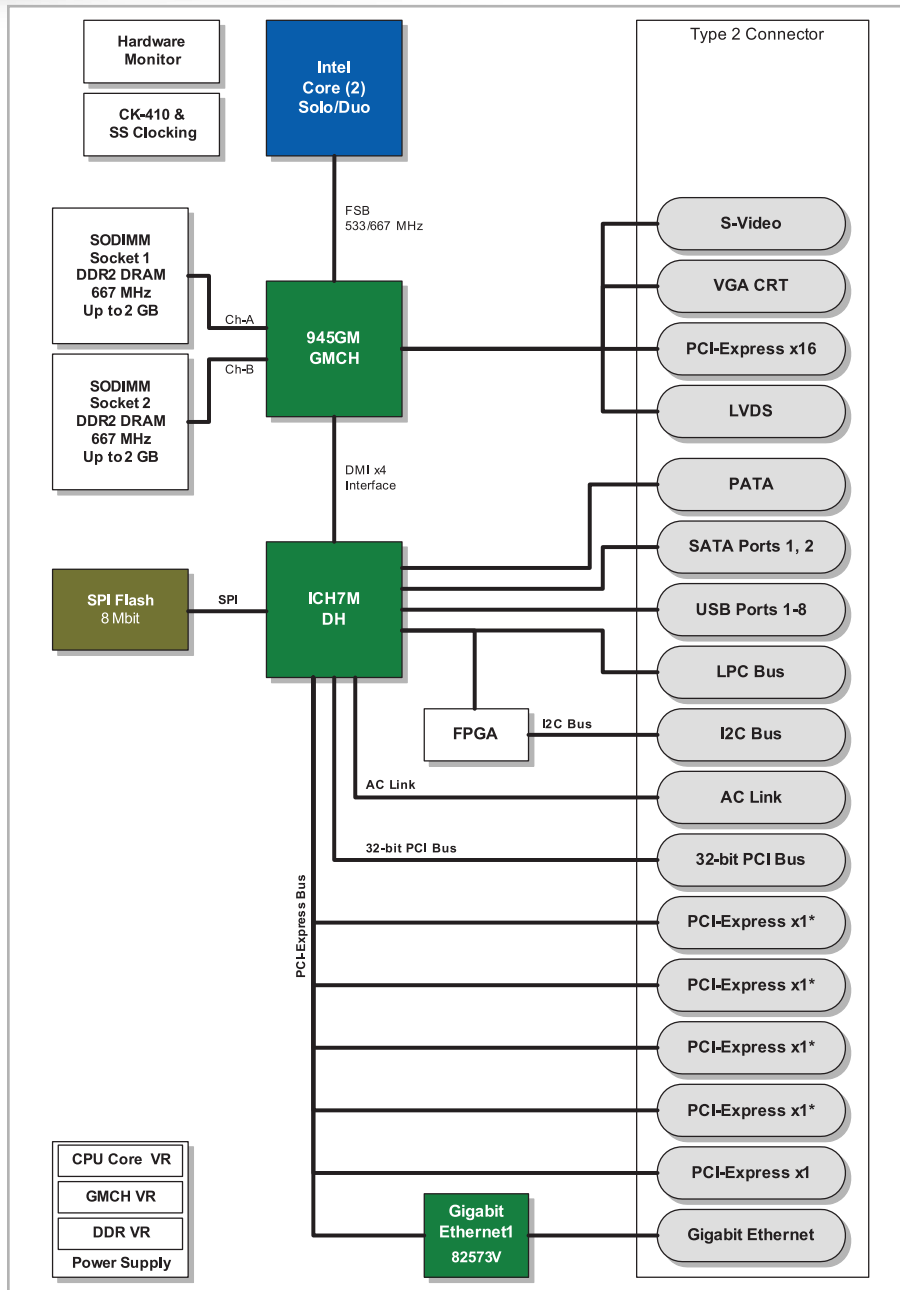

KIB1280

ATX form-factor compliant carrier board for ComExpress/ComExpress Extended Type II pinout modules.

Interfaces

- VGA, S-Video, LVDS
- 1xGbEthernet 10/100/1000-Base-T RJ45
- 1x16 PCI Express, 3x1 PCI Express, 3xPCI
- 6xUSB2.0
- IDE UltraATA, 4xSATA, CF Type I/II socket with IDE interface

- 2xCOM232, LPT, FDD, PS/2
- 2xExpress™ Card slots
- Audio line-in/out, MIC
- LPC interface, SMBUS, PLCC, fan connector, control&signalling interfaces and LEDs, ATX power supply.

Please read User manual for complete product description.

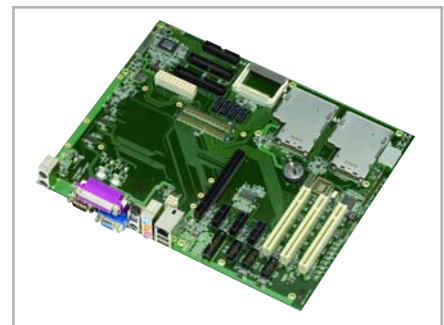

CPC1301

COM Express module based on Intel® Core® 2 Duo CPU

Ordering Information

CPC1301 Configuration

CPC1301 - 01 - C2D1.5 - I \Options

Device Type

CPC1301 CPC1301 COM Express Intel® Core® Module, Intel® 945GM chipset, DDR2 SODIMM, Gigabit Ethernet, LVDS, PCI-Express, 8 USB, 2 SATA

Processor

CD1.66 Intel® Core Duo 1.66 GHz LV
 CS1.06 Intel® Celeron M 423 1.06 GHz
 C2D1.5 Intel® Core 2 Duo 1.5 GHz
 C2D2.16 Intel® Core 2 Duo 2.16 GHz

SODIMM Memory Module

SC-SODIMM-DDR2-1024 1024 MB, Single channel
 (C - commercial, I - industrial)
 DC-SODIMM-DDR2-2048 2048 MB, Dual channel
 (C - commercial, I - industrial)
 DC-SODIMM-DDR2-4096 4096 MB, Dual channel
 (C - commercial, I - industrial)

Temperature Ranges

I Industrial Range, -40...+85°C
 C Commercial Range, 0...+70°C

Options

\xxx Choose available options from the table

CPC1301 Available Options

Coating	
\COATED	Protective Coating
Radiator	
\R3	Ribbed radiator, no fan, lengthwise orientation OSX77
\R3F	Ribbed radiator, fan, lengthwise orientation OSX77
\R4	Ribbed radiator, no fan, widthwise orientation OSX77
\R4F	Ribbed radiator, fan, widthwise orientation OSX77
Heatspreader, heatsink and fan (preliminary information):	
\R	Heatspreader (with CS1.06 only)
\R3	Ribbed heatsink, no fan, ribs oriented lengthwise, OSX77
\R3F	Ribbed heatsink, with fan, ribs oriented lengthwise, OSX77
\R4	Ribbed heatsink, no fan, ribs oriented widthwise, OSX77
\R4F	Ribbed heatsink, with fan, ribs oriented widthwise, OSX77
\R5	Ribbed heatsink, no fan, ribs oriented lengthwise, OSX98
\R5F	Ribbed heatsink, with fan, ribs oriented lengthwise, OSX98
\R6	Ribbed heatsink, no fan, ribs oriented widthwise, OSX98
\R6F	Ribbed heatsink, with fan, ribs oriented widthwise, OSX98

Other configurations and options are available upon request.

Example

CPC1301-01-C2D1.5-DC-SODIMM-DDR2-4096-\COATED\R3F

CPC1301 COM Express Intel® Core® 2 Duo Module, Intel® 945GM chipset, DDR2 SODIMM, Gigabit Ethernet, LVDS, 5 x1 PCI-Express, 8 USB, 2 SATA Intel® Core 2 Duo 1.5 GHz 4096 MB DDR2 SDRAM in SODIMM sockets, Dual channel, Industrial Protective coating Ribbed heatsink, with fan, ribs oriented lengthwise, OSX77

Ver. 1.4 2011

Product specifications are subject to change without notice

Applications



Mobile



Industrial Automation



Communications



Embedded

Corporate Offices

FASTWEL GROUP Co. Ltd
 108 Profsoyuznaya str.
 Moscow, Russia 117437
 Tel: +7 (495) 232-1681
 Fax: +7 (495) 232-1654
 E-mail: info@fastwel.com
 Web: www.fastwel.com

FASTWEL Corporation US
 55 Washington street, Suite 310
 Brooklyn, NY 11201
 Tel: 1.718.554.3686
 Fax: 1.718.797.0600
 Toll free: 1.877.787.8443
 (1.877.RURUGGED)
 E-mail: info@fastwel.com

FASTWEL Asia
 6F., No. 118, Ln.235, Baoqiao
 Rd., Xindian Dist,
 New Taipei City, Taiwan, R.O.C.
 Tel: +886-2-8912 1938
 Fax: +886-2-8912 1939
 E-mail: asia@fastwel.com

READY FOR



RoHS



Fastwel